

hard material matters

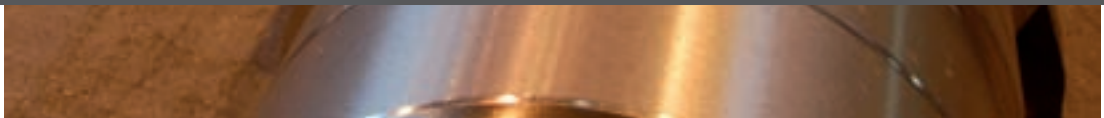

Tools and inserts for roll machining



CERATIZIT – secrets of success

Secrets of success

- CERATIZIT is your partner for exceptional hard material solutions. Hard materials and tools from CERATIZIT – our solutions to complex problems are an integral part of our customers' success. Our products guarantee: economy – long life – speed! And it is precisely this combination which gives our business partners a direct competitive advantage.
- Premier performance is only possible through a total appreciation of the requirements of our business partners. A performance achieved through flexible thinking and continuous dialogue with our customers. A pioneering spirit and a deep understanding of powder metallurgy characterize the history of CERATIZIT. One of the attributes of our company philosophy is the search for perfection: target oriented – sustainably – passionately!
- Intensive research and development activities, taking into account the precise requirements and working processes of the customer, are today's investment for the solutions of tomorrow – and beyond.

Corporate values















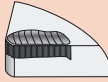

- 1 The views and focus of our business partners matter
- 2 Innovative and flexible thinking matters
- 3 Communication matters
- 4 Employee development matters
- 5 Professionalism matters
- 6 Our environment matters

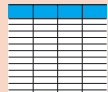

Tailored cutting tool solutions

- Cutting materials, coatings, inserts, tooling systems and machining solutions – all this is included in the cutting tool division at CERATIZIT.
- Worldwide well-known companies process advanced materials applying cutting tool products from CERATIZIT: from the automotive industry to the aerospace industry, mechanical engineering, tool construction to the oil industry.
- The basis of these long-term business relations is the faith of the customers in the extensive know-how of the carbide specialists.

Contents

Introduction	Inserts	Tools	Technical information
 A4-A5	 B2-B5	 C2-C4	 D2-D5
 A6-A9	 B6-B25	 C5	 D6-D8
 A10-A11	 B26-B27	 C6-C16	 D8-D10
 A12-A13	Special inserts B29	 C17-C21	Special tools D11
 A15		 C22	
 A17-A19			



A4-A5

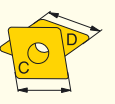

A6-A9



A10-A11



A12-13



A15



A17-A19

CERATIZIT – strengths and services

Strengths
and
services

A4

Benefits

A5

Designation
system

A6-A9

Grade
overview

A10-A11

Chip
grooves

A12-A13

Clamping
systems

A15

OEM
services

A16

Introduction

A17-A19

Strengths and services

- High competence in production for carbides and all other hard materials such as PCD, CBN, ceramic ...
- Market leader in coating technology (CVD PVD), innovative developments such as 'HYPERCOAT'
- Application advice, customized developments
- Production sites in all important industrialized regions

HYPERCOAT



- Worldwide consulting of our customers supported by experienced application engineers on site
- Supporting machine manufacturers to achieve maximum performance
- Comprehensive standard programme
- Continuous development of cutting materials and geometries

Benefits

CERATIZIT – competence in roll machining

SUCCESS FACTORS

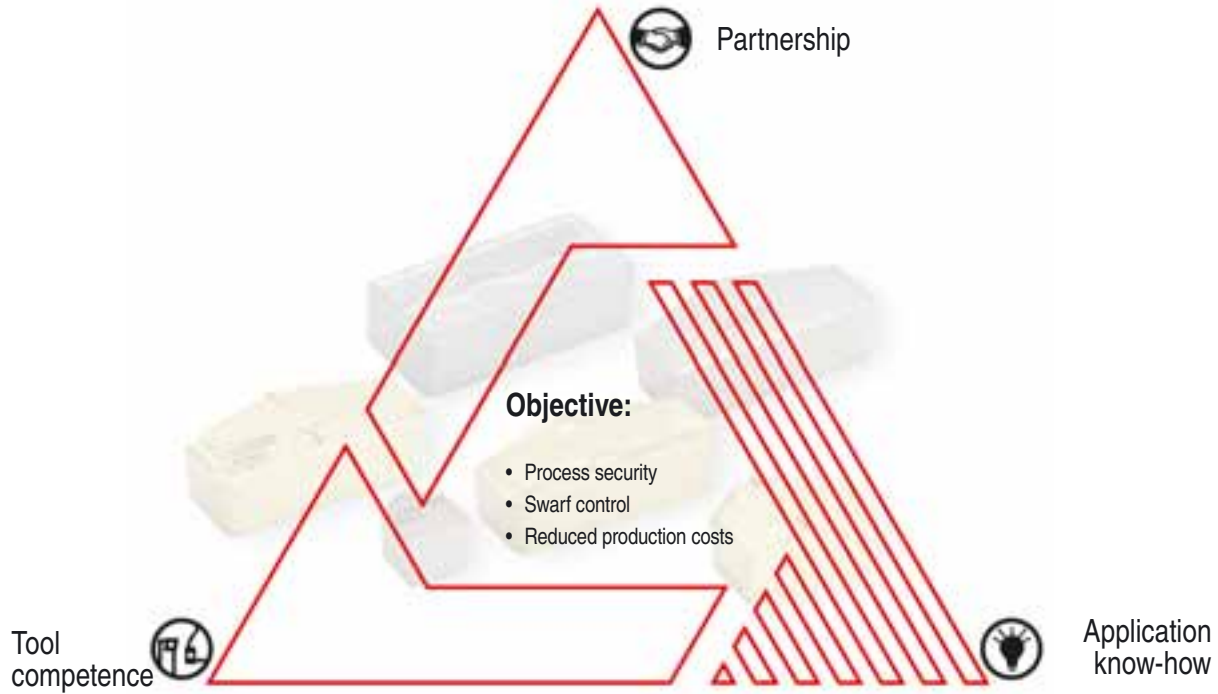

Production cost saving thanks to optimum tooling solution

cost reduced by 27%

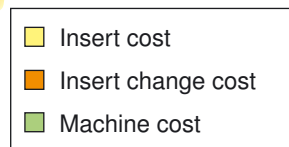

A4-A5



A6-A9



A10-A11



A12-13



A15



A17-A19

CERATIZIT designation system

Strengths and services

A4

Benefits

A5

Designation system

A6-A9

Grade overview

A10-A11

Chip grooves

A12-A13

Clamping systems

A15

OEM services

A16

Introduction

A17-A19

Designation system for parting and grooving inserts

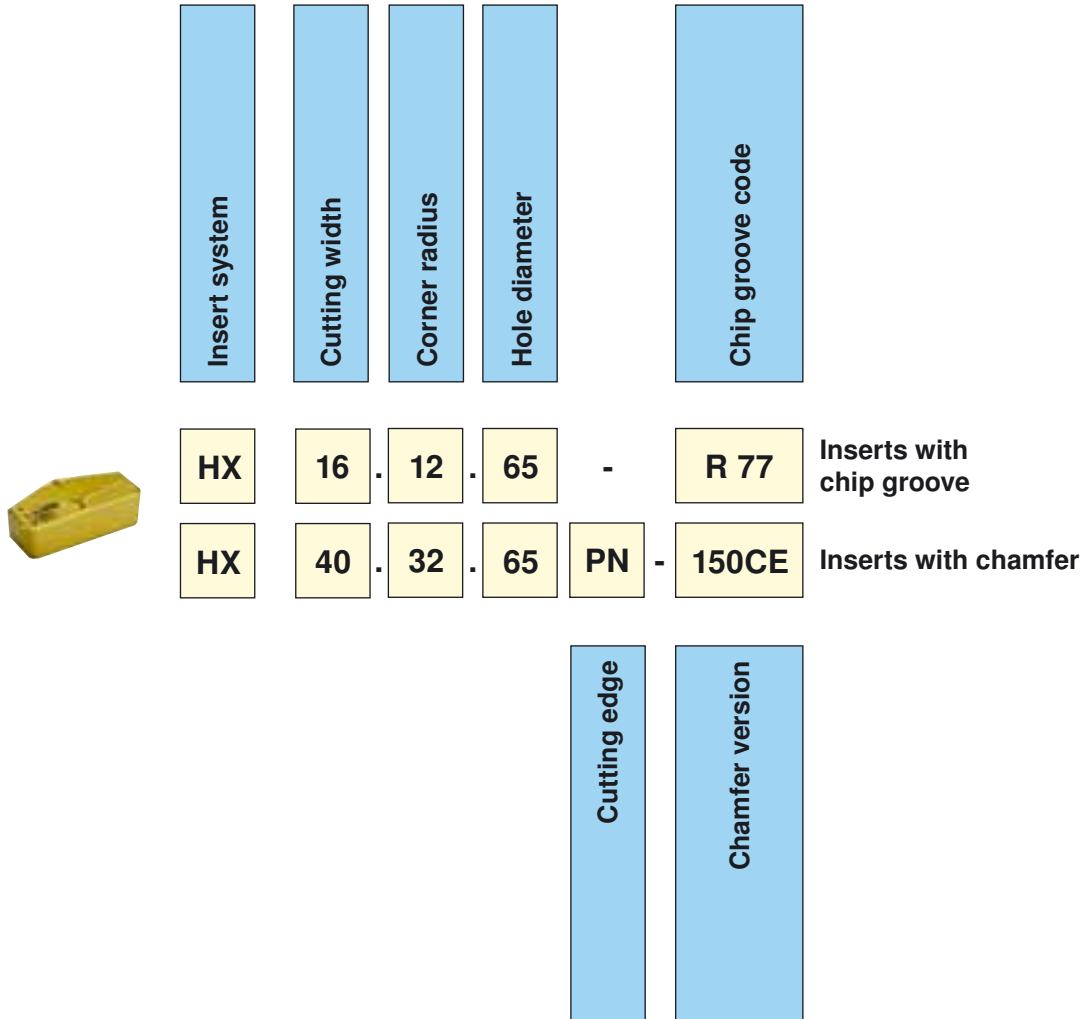

Designation system for turning inserts

Our designations for turning inserts are according to the ISO designation system. **Position 10** is an additional information for our chamfer designation.

CERATIZIT designation system

CERATIZIT chamfer key

In inserts without chip groove both cutting edge type and correct chamfer version are decisive. For this reason the designation system has been extended by the following key for chamfers.

Designation according to ISO	CERATIZIT	Definition
Cutting edge	Chamfer	Chamfer width (b) x angle (γ, γ_1, γ_2)
SN (chamfered and honed)	050D	0,50 x 20°
TN (chamfered)	200D	2,00 x 20°
PN (double-chamfered and honed)	100CF	1,00 x 15° + 30° Chamfer width refers only to γ_1

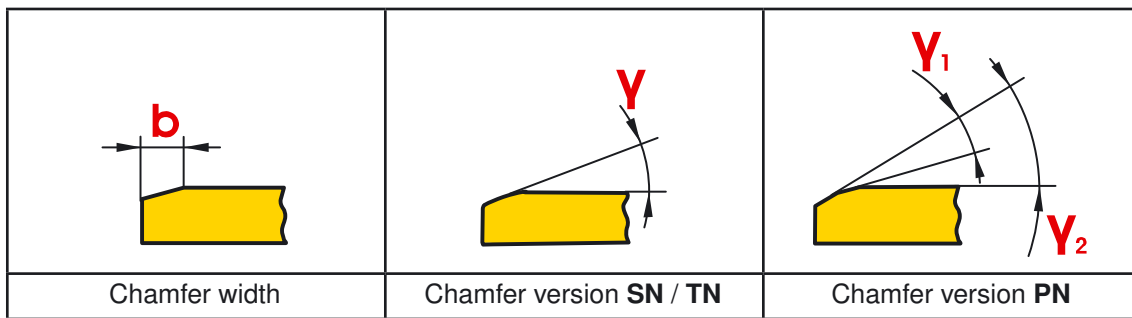

Codes for angle γ :

A = 05° D = 20°
 B = 10° E = 25°
 C = 15° F = 30°

Examples:

LNMN 6688SN-040D chamfer width: 0.40 mm, angle γ_1 : 20°
 LNMN 6688SN-100B chamfer width: 1.00 mm, angle γ_1 : 10°
 LNMN 6688PN-150CE chamfer width: 1.50 mm, angle γ_1 : 15°, angle γ_2 : 25°
 HX 40.32.65PN-150CE chamfer width: 1.50 mm, angle γ_1 : 15°, angle γ_2 : 25°
 HX 45.32.65PN-125CE chamfer width: 1.25 mm, angle γ_1 : 15°, angle γ_2 : 25°



A4-A5



A6-A9



A10-A11



A12-13



A15



A17-A19

CERATIZIT designation system

Strengths and services

A4

Benefits

A5

Designation system

A6-A9

Grade overview

A10-A11

Chip grooves

A12-A13

Clamping systems

A15

OEM services

A16

Introduction

A17-A19

A8

Designation system for tools

The designation system consists of 5 parts which describe the tool characteristics:

- 1) General information about type/version of the tool
- 2) Machine connection (in green)
- 3) Cartridge type (in blue)
- 4) Insert type (in yellow)
- 5) Additional information on depth of cut and approach angle



Example: designation system for tool holders with integral insert seat

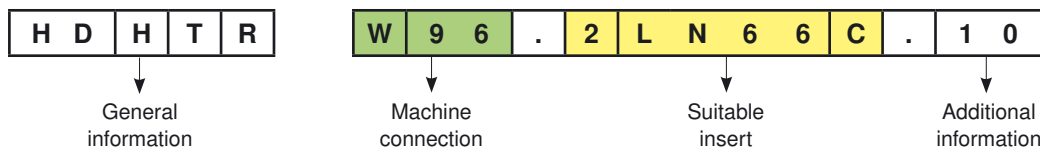

This integral tool (no cartridge) designation doesn't need the part for the cartridge designation. See table below.

<p>General information</p> <table border="1" style="margin-left: auto; margin-right: auto; text-align: center; border-collapse: collapse;"> <tr> <td style="padding: 2px;">H</td> <td style="padding: 2px;">D</td> <td style="padding: 2px;">H</td> <td style="padding: 2px;">T</td> <td style="padding: 2px;">R</td> </tr> <tr> <td style="padding: 2px;">(1)</td> <td style="padding: 2px;">(2)</td> <td style="padding: 2px;">(3)</td> <td style="padding: 2px;">(4)</td> <td></td> </tr> </table>	H	D	H	T	R	(1)	(2)	(3)	(4)		<p>(1) HD = heavy duty (2) H = tool holder / C = cartridge (3) T = turning / G = grooving (4) R = direction of cut</p>
H	D	H	T	R							
(1)	(2)	(3)	(4)								
<p>Machine connection</p> <div style="display: flex; align-items: center;"> <table border="1" style="margin-right: 10px; text-align: center; border-collapse: collapse;"> <tr> <td style="padding: 2px;">W</td> <td style="padding: 2px;">9</td> <td style="padding: 2px;">6</td> </tr> </table> <table border="1" style="text-align: center; border-collapse: collapse;"> <tr> <td style="padding: 2px;">6</td> <td style="padding: 2px;">0</td> <td style="padding: 2px;">6</td> <td style="padding: 2px;">0</td> <td style="padding: 2px;">V</td> </tr> </table> </div>	W	9	6	6	0	6	0	V	<p>W/C/H/S/K .. type of connection 96/124 .. width of tool holder</p> <p>Tool holder with square shank: 5050U.. shank 50x50, length 350 6060V.. shank 60x60, length 400</p>		
W	9	6									
6	0	6	0	V							
<p>Cartridge type</p> <div style="display: flex; align-items: center;"> <table border="1" style="margin-right: 10px; text-align: center; border-collapse: collapse;"> <tr> <td style="padding: 2px;">D</td> <td style="padding: 2px;">5</td> <td style="padding: 2px;">0</td> </tr> </table> <table border="1" style="text-align: center; border-collapse: collapse;"> <tr> <td style="padding: 2px;">.</td> <td style="padding: 2px;">4</td> <td style="padding: 2px;">4</td> </tr> </table> </div>	D	5	0	.	4	4	<p>D = double / S = single 50.. = tip height / cutting width 44 = height of cartridge</p>				
D	5	0									
.	4	4									
<p>Insert type</p> <div style="display: flex; align-items: center;"> <table border="1" style="text-align: center; border-collapse: collapse;"> <tr> <td style="padding: 2px;">1</td> <td style="padding: 2px;">H</td> <td style="padding: 2px;">X</td> <td style="padding: 2px;">1</td> <td style="padding: 2px;">6</td> <td style="padding: 2px;">P</td> </tr> </table> </div>	1	H	X	1	6	P	<p>1.. = number of inserts HX16.. = insert type P / C / S.. = clamping through pin / top clamp / screw</p>				
1	H	X	1	6	P						
<p>Additional information</p> <p style="margin-left: 20px;">- <table border="1" style="text-align: center; border-collapse: collapse;"> <tr> <td style="padding: 2px;">0</td> <td style="padding: 2px;">7</td> <td style="padding: 2px;">0</td> </tr> </table></p> <p style="margin-left: 20px;"><table border="1" style="text-align: center; border-collapse: collapse;"> <tr> <td style="padding: 2px;">.</td> <td style="padding: 2px;">08</td> </tr> </table></p>	0	7	0	.	08	<p>070 = maximum parting & grooving depth 08 = approach angle when turning</p>					
0	7	0									
.	08										

CERATIZIT designation system

Tool holder with integral insert seat



H	D	H	T	R
---	---	---	---	---

W	9	6	.	2	L	N	6	6	C	.	1	0
---	---	---	---	---	---	---	---	---	---	---	---	---



A4-A5

Tool holder for cartridges



H	D	H	G	R
---	---	---	---	---

W	9	6	.	G	4	0	-	0	7	0
---	---	---	---	---	---	---	---	---	---	---

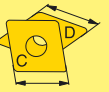

A6-A9

Tool holder with square shank and integral insert seat



H	D	H	T	R
---	---	---	---	---

6	0	6	0	V	.	1	L	N	6	6	C	.	08
---	---	---	---	---	---	---	---	---	---	---	---	---	----



A12-13

Tool holder with square shank for cartridges

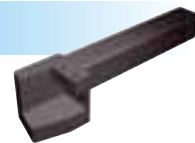

H	D	H	T	R
---	---	---	---	---

6	0	6	0	V	.	S	4	0
---	---	---	---	---	---	---	---	---



A15

Cartridge for turning



H	D	C	T	R
---	---	---	---	---

1	L	N	6	6	C	.	D	5	0	.	08
---	---	---	---	---	---	---	---	---	---	---	----



A17-A19

Cartridge for parting and grooving



H	D	C	G	N
---	---	---	---	---

1	H	X	1	6	P	.	4	4
---	---	---	---	---	---	---	---	---

Grade overview

Turning, parting and grooving

Strengths and services
A4
Benefits
A5
Designation system
A6-A9
Grade overview
A10-A11
Chip grooves
A12-A13
Clamping systems
A15
OEM services
A16
Introduction
A17-A19

Grade designation	Standard designation	Cutting material	Application range								A	R	F	N	S	H			
			01	05	10	15	20	25	30	35	40	45	50	Steel	Stainless steel	Cast iron	Non ferrous metals	Heat resistant materials	Hard materials
											●	○	●	○	●	○	●	○	
LP105	HC-K05	C	■	■	■								○	■	●	■	■	■	
MT105	HC-M10	C		■	■								○	■	○	■	■	■	
	HC-K05	C	■	■	■								○	■	●	■	■	■	
LP100	HC-K10	C		■	■	■							○	■	■	●	■	■	
CTC1110	HC-P10	C		■	■	■	■						●	■	■	■	■	■	
	HC-M10	C			■	■							○	■	○	■	■	○	
	HC-K15	C		■	■	■	■						○	■	■	●	■	■	
CTC3110	HC-P10	C		■	■	■							○	■	■	■	■	■	
	HC-K10	C		■	■	■							○	■	■	●	■	■	
MT100	HC-P10	C	■	■	■								●	■	■	■	■	■	
	HC-K10	C		■	■								○	■	■	○	■	■	
LP202	HC-P15	C			■	■	■						●	■	■	■	■	■	
	HC-K20	C				■	■						○	■	○	■	■	■	
CTC1115	HC-P15	C		■	■	■	■						●	■	■	■	■	■	
	HC-M15	C			■	■							○	■	○	■	■	○	
	HC-K15	C		■	■	■	■						○	■	■	○	■	■	
LP2002	HC-P25	C			■	■	■	■					●	■	■	■	■	■	
CTC1125	HC-P25	C			■	■	■	■					●	■	■	■	■	■	
	HC-M25	C				■	■						○	■	○	■	■	■	
	HC-K20	C		■	■	■	■						○	■	■	○	■	■	
CTP1127	HC-P25	C			■	■	■	■					●	■	○	■	■	■	
CTC1130	HC-P30	C				■	■	■	■				●	■	■	■	■	■	
	HC-M20	C				■	■						○	■	○	■	■	■	
	HC-K20	C		■	■	■	■						○	■	■	●	■	■	
CTC1135	HC-P35	C				■	■	■	■	■			●	■	■	■	■	■	
	HC-M25	C				■	■						○	■	○	■	■	○	
MTM35	HC-P35	C					■	■	■	■			●	■	■	■	■	■	
LP4002	HC-P35	C						■	■	■	■		●	■	■	■	■	■	
	HC-M20	C				■	■						○	■	●	■	■	■	

● Main application
○ Extended application



Grade overview

Turning, parting & grooving, milling

Grade designation	Standard designation	Cutting material	Application range								A	R	F	N	S	H									
			01	05	10	15	20	25	30	35	40	45	50	Steel	Stainless steel	Cast iron	Non ferrous metals	Heat resistant materials	Hard materials						
LP242	HC-P40	C											●	●	●	●	●								
	HC-M20	C											●	●	●	●	●								
CTC2135	HC-P35	C											○	●	●	●	●								
	HC-M30	C											●	●	●	●	●								
H01X	HW-K05	W																							
TSM05	HW-K01	W																							
H05X	HW-K05	W																							
			01	05	10	15	20	25	30	35	40	45	50	●	Main application					○	Extended application				

Grade designation	Standard designation	Cutting material	Application range							A	R	F	N	S	H					
			0	05	10	15	20	25	Steel	Stainless steel	Cast iron	Non ferrous metals	Heat resistant materials	Hard materials						
CTN3107 *	CN-K10	N																		
CTN3110	CN-K10	N																		
CTM3110	CC-K10	M																		
CTS3105	CM-K10	M																		
TA100	BN-K03	B																		
TA120	BN-K05	B																		
			0	05	10	15	20	25	●	Main application					○	Extended application				

Milling

Grade designation	Standard designation	Cutting material	Application range								A	R	F	N	S	H									
			01	05	10	15	20	25	30	35	40	45	50	Steel	Stainless steel	Cast iron	Non ferrous metals	Heat resistant materials	Hard materials						
CTC3215	HC-K15	C																							
CTP1235	HC-P35	P																							
			01	05	10	15	20	25	30	35	40	45	50	●	Main application					○	Extended application				

* For special applications. Only upon request.



A4-A5



A6-A9



A10-A11



A12-13











A15



A17-A19





Chip grooves

HD inserts

Code	Insert	Application	Conditions	Cutting speed [m/min]	Feed rate [mm/rev]
-R70		Part-off, grooving and copy operations of steel and cast iron	Heavy machining under stable conditions	30 - 80	0.3 - 1.5
-R71		Part-off, grooving and copy operations of steel and cast iron	Heavy machining under unstable conditions	30 - 80	0.2 - 1.0
-R73		Part-off, grooving and copy operations of steel	Heavy machining under unstable conditions	30 - 60	0.3 - 1.0
-R75		Part-off, grooving and copy operations of steel	Machining on less powerful machines or with material tending to adhesion	30 - 50	0.2 - 0.6
-R77		Parting and grooving of steel	Heavy machining with difficult swarf control	30 - 60	0.4 - 1.2
-R79		Part-off, grooving and copy operations of steel and cast iron	Heavy machining under stable conditions	30 - 60	0.5 - 1.5
-R90		Turning of steel	Heavy machining under unstable conditions	25 - 80	1.0 - 2.0
-R91		Turning of steel	Heavy machining under unstable conditions	30 - 80	1.0 - 2.0

Chip grooves

HD inserts

Code	Insert	Application	Conditions	Cutting speed [m/min]	Feed rate [mm/rev]
-R93		Turning of steel and cast iron	Heavy machining under stable conditions	30 - 80	1.0 - 2.0
-R95		Turning of steel and cast iron	Heavy machining under stable conditions	30 - 80	1.0 - 2.5
-R96		Turning of cast steel	Heavy machining with difficult swarf control	25 - 80	1.0 - 2.2
-R98		Turning of steel	Turning of steel and cast iron	25 - 80	1.2 - 2.5
-R99		Turning of steel and cast iron	Heavy machining at very high feed rates	25 - 70	1.5 - 2.6



A4-A5



A6-A9



A10-A11



A12-13



A15



A17-A19

**Strengths
and
services**

A4

Benefits

A5

**Designation
system**

A6-A9

**Grade
overview**

A10-A11

**Chip
grooves**

A12-A13

**Clamping
systems**

A15

**OEM
services**

A16

Introduction

A17-A19



Clamping systems

Clamping through pin (P)

Inserts with a clamping hole are mounted applying the tried and tested pin clamping system. The insert is pulled onto the seating faces from below.



- Clamping element
- Insert
- Shim

Top clamp (C)

Plain inserts (no hole) are simply clamped from above.

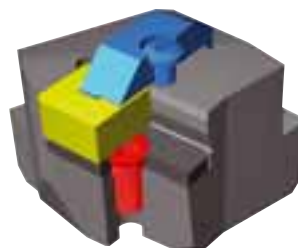

- Clamping screw and claw
- Insert
- Shim
- Shim pin

Clamping with a screw (S)

The form lock screw guarantees a safe connection of the insert and the tool holder. Chip evacuation is not hindered by obstructive clamping elements. Due to the neutral insert position the effective rake angle is identical to that of the insert form and geometry.



- Clamping screw
- Insert
- Shim
- Threaded shim screw



A4-A5

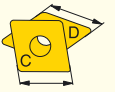

A6-A9



A10-A11



A12-13



A15



A17-A19



OEM Services

Together we create real solutions

CERATIZIT offers tailor-made complete solutions for optimum machining.

1. Specific team for **OEM services** to guarantee professional project processing
2. Close cooperation with machine manufacturers
3. Complete machining concepts and tooling solutions:
 - ▶ Workflow
 - ▶ Tools
 - ▶ Cutting parameters
 - ▶ Tools necessary for a specific application
 - ▶ Process times
 - ▶ Process costs
4. Support for acceptance and commissioning runs
5. Detailed project documentation
6. Worldwide distribution and service network to support process optimization

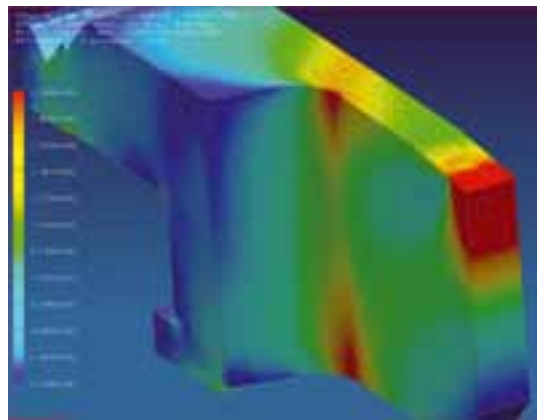
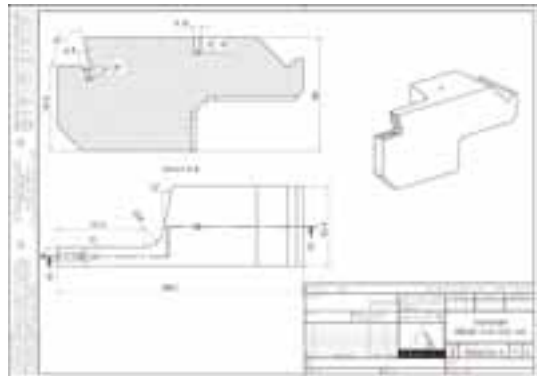

◆ When investing in machines, make use of CERATIZIT's **OEM Service** to ensure optimum productivity — from the first day onwards!!

Grooving neck 40-50 ShC

Operation: **5**

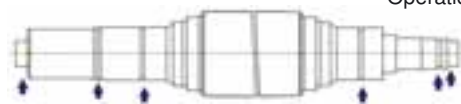

Tool holder



HDHGR W96C25-070
HDHGL W96C25-070

Cartridge



HDCGN 1HX25.44

Insert



HX 25.25.65PN-150CE

Cutting data

Grooving:
 V_c : 30-50 m/min
 f : 0,3-0,6 mm/rev.
 a_p : 25 mm

hard material matters

Introduction

PARTING AND GROOVING

Machine connections for tool holders



All tool holders are available for the systems C, K, H, W and S

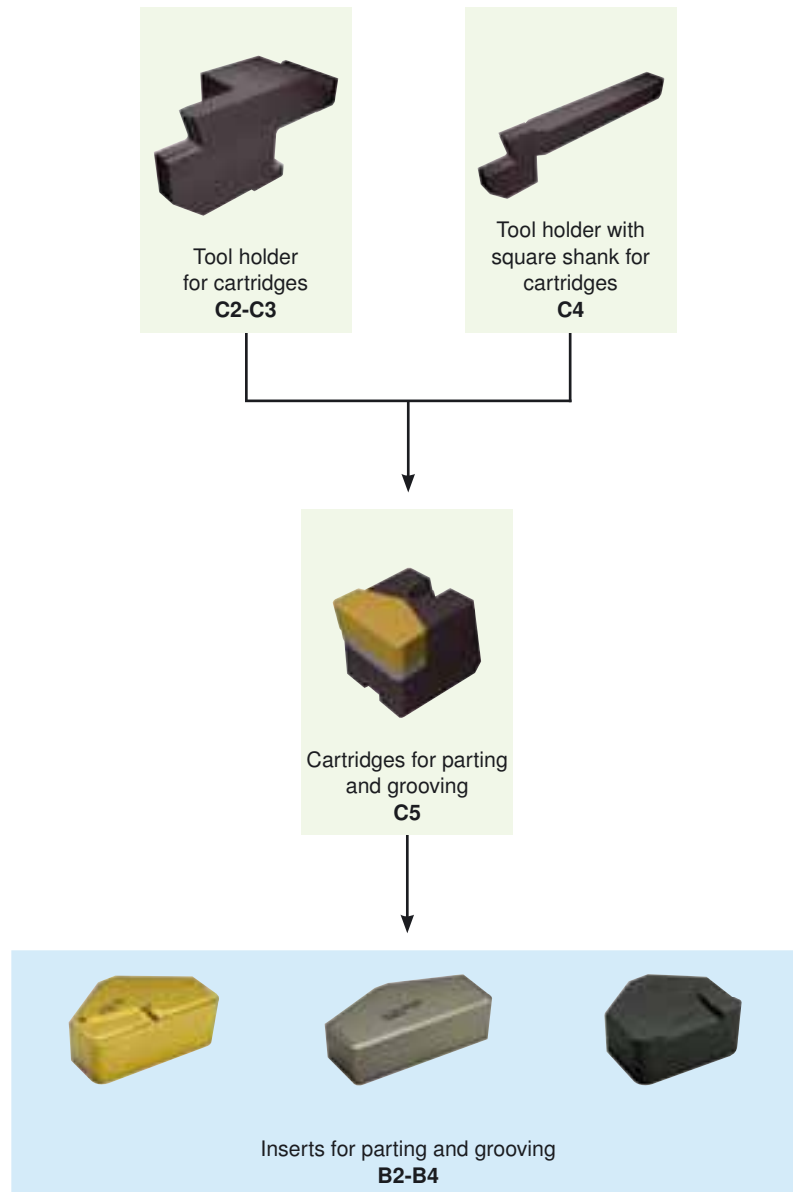

A4-A5



A6-A9



A10-A11



A12-13



A15



A17-A19

A17

Introduction

TURNING

Strengths and services

A4

Benefits

A5

Designation system

A6-A9

Grade overview

A10-A11

Chip grooves

A12-A13

Clamping systems

A15

OEM services

A16

Introduction

A17-A19

Machine connections for tool holders



All tool holders are available for the systems C, K, H, W and S

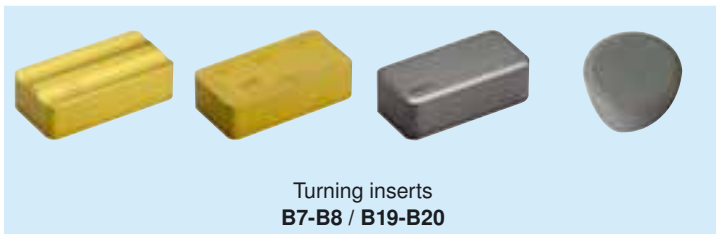
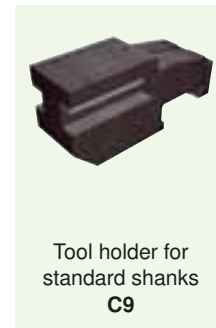
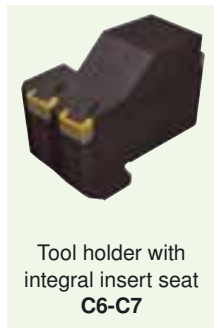

All suitable inserts from our standard programme



Main catalogue 'Tools and inserts for turning', No. 183

Introduction

TURNING

Shank tool holders



All suitable inserts from our standard programme



Main catalogue
'Tools and inserts for turning',
No. 183



A4-A5



A6-A9



A10-A11



A12-13



A15



A17-A19

Parting and grooving inserts

HX 16 / HX 20

HX16-20



B2

HX25-32



B3

HX40-50



B4



s [mm]	Type, description	Previous designation	LP105		MT105		LP100		MT100		CTN3110		CTM3110		r [mm]	d ₁ [mm]	
			●	○	●	○	●	○	●	○	●	○					
16	HX 16.12.65-R71	82046	●											1,2	6,5	pin	
16	HX 16.12.65-R77	40479	●											1,2	6,5	pin	
16	HX 16.12.65PN-090CE	40480	●							●				1,2	6,5	pin	
20	HX 20.16.65-R71	82045			●									1,6	6,5	pin	
20	HX 20.16.65-R77	40350	●			●								1,6	6,5	pin	
20	HX 20.16.65PN-120CE	40478	●							●	●			1,6	6,5	pin	



Steel	●	○	●	○	●	○	●	○	●	○
Stainless	○	○	○	○	○	○	○	○	○	○
Cast iron	●	○	●	○	●	○	●	○	●	○
Non ferrous metals	○	○	○	○	○	○	○	○	○	○
Heat resistant	○	○	○	○	○	○	○	○	○	○
Hard materials	○	○	○	○	○	○	○	○	○	○

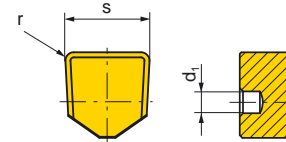

- Main application
- Extended application
- International CERATIZIT range

Ordering example: 30 pieces HX 16.12.65-R71 MT105



	HDCGN 1HX16-20						
		C5					

Parting and grooving inserts

HX 25 / HX 32



s [mm]	Type, description	Previous designation						r [mm]	d ₁ [mm]	
			LP105	MT105	MT100	LP2002	CTN3110			
25	HX 25.16.65-R71	82171		●	●			1,6	6,5	pin
25	HX 25.16.65PN-040CE	82168	●					1,6	6,5	pin
25	HX 25.20.65-R75	83606	●		●	●		2,0	6,5	pin
25	HX 25.25.65-R77	39421	●					2,5	6,5	pin
25	HX 25.25.65PN-150CE	39420	●				●	2,5	6,5	pin
32	HX 32.16.65-R71	81670		●				1,6	6,5	pin
32	HX 32.16.65PN-040CE	82169	●					1,6	6,5	pin
32	HX 32.20.65-R75	83605				●		2,0	6,5	pin
32	HX 32.32.65-R70	81666				●		3,2	6,5	pin
32	HX 32.32.65-R77	39423	●					3,2	6,5	pin
32	HX 32.32.65PN-150CE	39422	●				●	3,2	6,5	pin



Steel	○	●	●	●	●	●
Stainless	○					
Cast iron	●	●	○	●	●	●
Non ferrous metals						
Heat resistant						
Hard materials						

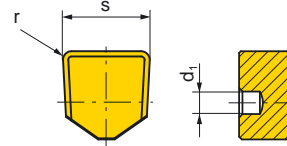

- Main application
- Extended application
- International CERATIZIT range

Ordering example: 30 pieces HX 32.20.65-R75 LP2002



	HDCGN 1HX25-32					
		C5				



B2-5



B6-B25



B26-B27

Special inserts

B29

Parting and grooving inserts

HX 40 / HX 45 / HX 50

HX16-20



B2

HX25-32



B3

HX40-50



B4

s [mm]	Type, description	Previous designation	CERATIZIT range							r [mm]	d ₁ [mm]	
			LP105	LP2002	LP035	MTM35	CTN3110	CTM3110	H05X			
40	HX 40.25.65PN-045CE	82170	●							2,5	6,5	pin
40	HX 40.32.65-R70	81665	●	●		●				3,2	6,5	pin
40	HX 40.32P.65-R73	83779				●				3,2	6,5	pin
40	HX 40.32.65-R75	83604		●						3,2	6,5	pin
40	HX 40.32.65-R77	39414	●							3,2	6,5	pin
40	HX 40.32.65PN-150CE	39413	●					●	●	3,2	6,5	pin
45	HX 45.32.65-R77	39250	●							3,2	6,5	pin
45	HX 45.32.65PN-150CE	39415	●					●		3,2	6,5	pin
45	HX 45.35.65-R70	88833	●	●						3,5	6,5	pin
50	HX 50.24.65PN-150CE	81934						●	●	2,4	6,5	pin
50	HX 50.24P.65PN-090A	82324						●	●	2,4	6,5	pin
50	HX 50.35.65-R70	81005	●	●						3,5	6,5	pin
50	HX 50.35.65-R77	39410	●							3,5	6,5	pin
50	HX 50.35.65-R79	40486	●		●					3,5	6,5	pin
50	HX 50.35.65PN-150CE	39416						●	●	3,5	6,5	pin

	Steel	○	●	●	●	●	●	●	●	●	●	●
	Stainless	○	●	●	●	●	●	●	●	●	●	●
	Cast iron	○	●	●	●	●	●	●	●	●	●	●
	Non ferrous metals	○	●	●	●	●	●	●	●	●	●	●
	Heat resistant	○	●	●	●	●	●	●	●	●	●	●
	Hard materials	○	●	●	●	●	●	●	●	●	●	●

● Main application
 ○ Extended application
 ● International CERATIZIT range

Ordering example: 30 pieces HX 50.35.65-R77 LP105

A12-A13

	HDCGN 1HX40-50					
		C5				

B4

Additional parting and grooving tools

For additional parting and grooving inserts and tools (cutting widths 2.2 - 9.7 mm) see our main catalogue

'The modular parting, grooving and threading system', No. 148

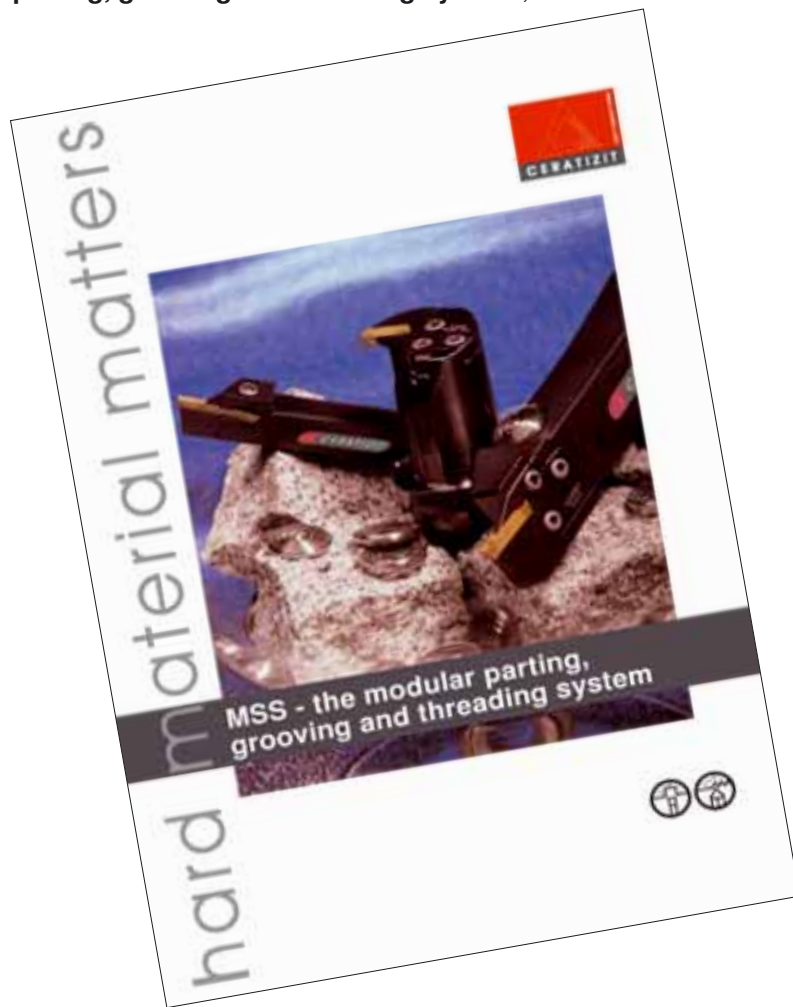

B2-5



B6-B25



B26-B27

Special inserts

B29

All tools from the main catalogue

'The modular parting, grooving and threading system', No. 148 can also be found in our product overview at www.e-techstore.com

 **-TECHSTORE**
www.ceratizit.com



B5

Turning inserts

SCMT 38

SCMT38



B6

LN..



B7-B8

80°



B9-B10

90°



B11

60°



B12

0°



B13

80°



B14-B15

55°



B16

0°



B17-B20

90°



B21-B23

60°



B24

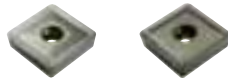

-SN

-R90

r [mm]	Type, description	L N R 	CERATIZIT RANGE				l [mm]	d [mm]	s [mm]	d ₁ [mm]	
			CTC1115	CTC1125	CTP1127	CTC1130					
3,20	SCMT 380932SN	N	●	●	●		38,10	38,10	9,52	8,70	
3,20	SCMT 380932SN-R90	N	●	●	●	●	38,10	38,10	9,52	8,70	
			Steel	●	●	●	●				
			Stainless	○	○	○	○				
			Cast iron	○	○	○	○				
			Non ferrous metals	○	○	○	○				
			Heat resistant	○	○	○	○				
			Hard materials								

- Main application
- Extended application
- International CERATIZIT range

Ordering example: 30 pieces SCMT 380932SN CTC1115

	HDHT.. SC38..				
	C16				

B6

Turning inserts

LNMN 6688



-040D



-100B



-150CE

r [mm]	Type, description	Previous designation							l [mm]	d [mm]	s [mm]	
			S26T	TSM05	CTC1125	CTC1130	CTN3110	CTM3110				
3,20	LNMN 6688SN-040D	-	●	●	●	●			38,10	19,05	12,70	top clamp
3,20	LNMN 6688SN-100B	-		●					38,10	19,05	12,70	top clamp
3,20	LNMN 6688PN-150CE	35677					●	●	38,10	19,05	12,70	top clamp
3,20	LNMN 6688PN-200CE	-						●	38,10	19,05	12,70	top clamp



Steel	●	●	●	●	●	●	●	●	●	●
Stainless	○	○	○	○	○	○	○	○	○	○
Cast iron	●	●	●	●	●	●	●	●	●	●
Non ferrous metals	○	○	○	○	○	○	○	○	○	○
Heat resistant	○	○	○	○	○	○	○	○	○	○
Hard materials									●	

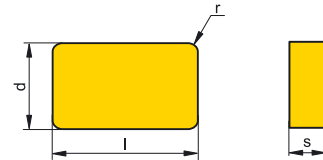

- Main application
- Extended application
- International CERATIZIT range

Ordering example: 30 pieces LNMN 6688PN-150CE CTN3110

	 HDHT.. 2LN66 C6-C7	 HDHT.. 1LN66 C12-C13	 HDCT.. 1LN66 C18		
---	---	---	---	--	--



B2-5



B6-B25



B26-B27

Special inserts

B29

Turning inserts

LN.. 40 / LN.. 50

SCMT38



B6

LN..



B7-B8

80°



B9-B10

90°



B11

60°



B12

0°



B13

80°



B14-B15

55°



B16

0°



B17-B20

90°



B21-B23

60°



B24

<p>-R90 -R91 -R93 -R95 -R96 -R98 -R99 -100E -150CE</p>																		
r [mm]	Type, description	Previous designation	LP105	LP100	MT100	CTC1115	LP2002	CTC1125	CTP1127	CTC1130	CTC1135	CTC2135	CTN3110	CTM3110	l [mm]	d [mm]	d ₁ [mm]	
3,50	LNMR 401435SN-R91	84431					●								40	25,4	6,5	pin
3,50	LNMR 401435SN-R93	38553-6.50						●				●	●		40	25,4	6,5	pin
3,50	LNMR 401435SN-R96	86844				●		●	●						40	25,4	6,5	pin
3,20	LNMR 501432SN-R90	-						●	●	●					50	25,4	6,5	pin
3,20	LNMR 501432SN-R98	-						●	●	●					50	25,4	6,5	pin
3,20	LNMR 501435SN-R99	-						●		●					50	25,4	6,5	pin
3,50	LNMR 501435SN-R91	84097					●								50	25,4	6,5	pin
3,50	LNMR 501435SN-R93	81963					●								50	25,4	6,5	pin
3,50	LNMR 501435SN-R95	40485	●				●	●				●			50	25,4	6,5	pin
3,50	LNMR 501435SN-R96	-				●		●							50	25,4	6,5	pin
3,20	LNMR 501232PN-150CE	35578											●	●	50	25,4	-	top clamp
3,50	LNMR 501435SN-100E	86626			●										50	25,4	-	top clamp
3,50	LNMR 501435SN-100E	40615	●	●	●										50	25,4	-	top clamp
			Steel	●	●	●	●	●	●	●	●	●	●	●				
			Stainless	●	●	○	○	○	○	○	○	○	○	○				
			Cast iron	●	●	●	●	●	●	●	●	●	●	●				
			Non ferrous metals	●	●	●	●	●	●	●	●	●	●	●				
			Heat resistant	●	●	○	○	○	○	○	○	○	○	○				
			Hard materials															

● Main application
○ Extended application
● International CERATIZIT range

Ordering example: 30 pieces LNMR 501435SN-R90 CTC1125

A12-A13

	<p>HDHT.. LN50..</p> <p>C14-C15</p>	<p>HDCT.. LN40-50</p> <p>C17 / C19</p>			
--	-------------------------------------	--	--	--	--

B8

Turning inserts

CN.. 16



r [mm]	Type, description	L N R 	CTC					CTN			l [mm]	d [mm]	s [mm]	d ₁ [mm]	
			CTC3110	CTC1110	CTC1115	CTC1125	CTC1130	CTC1135	CTC2135	CTN3110					CTM3110
0,80	CNGA 160608SN-028C	N								●		16,10	15,88	6,35	6,35
0,80	CNMA 160608EN	N	●									16,10	15,88	6,35	6,35
0,80	CNMG 160608EN-TM	N				●		●				16,10	15,88	6,35	6,35
1,20	CNMA 160612EN	N	●									16,10	15,88	6,35	6,35
1,20	CNMG 160612EN-TM	N				●		●				16,10	15,88	6,35	6,35
1,20	CNMG 160612EN-TMR	N	●		●	●	●		●			16,10	15,88	6,35	6,35
1,20	CNMG 160612EN-TRM	N		●		●						16,10	15,88	6,35	6,35
1,20	CNMM 160612EN-TR	N				●		●				16,10	15,88	6,35	6,35
1,20	CNMM 160612SN-TRR	N				●						16,10	15,88	6,35	6,35
1,20	CNMM 160612-WR	N						●				16,10	15,88	6,35	6,35
1,60	CNGA 160616SN-028C	N								●		16,10	15,88	6,35	6,35
1,60	CNGA 160616TN-020D	N									●	16,10	15,88	6,35	6,35
1,60	CNMA 160616EN	N	●									16,10	15,88	6,35	6,35
1,60	CNMG 160616EN-TMR	N	●			●						16,10	15,88	6,35	6,35
1,60	CNMG 160616EN-TRM	N		●			●					16,10	15,88	6,35	6,35
1,60	CNMM 160616EN-TR	N				●						16,10	15,88	6,35	6,35
1,60	CNMM 160616SN-TRR	N		●		●						16,10	15,88	6,35	6,35

	Steel	●	●	●	●	●	●	●	●	●	●	●	●	●	●
	Stainless	○	○	○	○	○	○	○	○	○	○	○	○	○	○
	Cast iron	●	●	●	●	●	●	●	●	●	●	●	●	●	●
	Non ferrous metals	○	○	○	○	○	○	○	○	○	○	○	○	○	○
	Heat resistant	○	○	○	○	○	○	○	○	○	○	○	○	○	○
	Hard materials														●

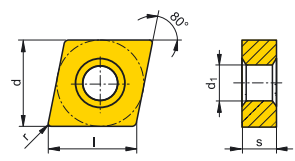

- Main application
- Extended application
- International CERATIZIT range

Ordering example: 10 pieces CNGA 160608SN-028C CTM3110



For tool holders and boring bars see main catalogue "Tools and inserts for turning", No. 183



B2-5

B6-B25

B26-B27

Special inserts

B29

Turning inserts

CN.. 19-25

SCMT38



B6

LN..



B7-B8

80°



B9-B10

90°



B11

60°



B12

0°



B13

80°



B14-B15

55°



B16

0°



B17-B20

90°



B21-B23

60°



B24



r [mm]	Type, description	LNR	CTC3110								l [mm]	d [mm]	s [mm]	d ₁ [mm]	
			MT100	LP202	CTC1115	LP2002	CTC1125	CTC1130	CTC1135	LP4002					CTC2135
1,20	CNMA 190612EN	N	●									19,30	19,05	6,35	7,94
1,20	CNMG 190612EN-TM	N						●				19,30	19,05	6,35	7,94
1,20	CNMG 190612EN-TMR	N			●		●	●	●		●	19,30	19,05	6,35	7,94
1,20	CNMM 190612EN-TR	N			●							19,30	19,05	6,35	7,94
1,20	CNMM 190612SN-TRR	N								●		19,30	19,05	6,35	7,94
1,60	CNMA 190616EN	N	●									19,30	19,05	6,35	7,94
1,60	CNMG 190616EN-TMR	N						●			●	19,30	19,05	6,35	7,94
1,60	CNMM 190616EN-TR	N						●				19,30	19,05	6,35	7,94
1,60	CNMM 190616SN-HT	N		●	●		●					19,30	19,05	6,35	7,94
1,60	CNMM 190616SN-R80	N							●			19,30	19,05	6,35	7,94
1,60	CNMM 190616SN-TRR	N						●		●		19,30	19,05	6,35	7,94
1,60	CNMM 190616-WR	N				●	●		●	●		19,30	19,05	6,35	7,94
2,40	CNMM 190624SN-HT	N		●	●		●	●				19,30	19,05	6,35	7,94
2,40	CNMM 190624SN-R80	N						●	●			19,30	19,05	6,35	7,94
2,40	CNMM 250724SN-HT	N		●							●	25,80	25,40	9,52	9,12
2,40	CNMG 250924-909	N			●		●			●		25,80	25,40	9,52	9,12
2,40	CNMM 250924SN-HT	N						●				25,80	25,40	9,52	9,12



Steel
Stainless
Cast iron
Non ferrous metals
Heat resistant
Hard materials

Steel	●	●	●	●	●	●	●	●	●	●
Stainless	○	○	○	○	○	○	○	○	○	○
Cast iron	●	●	●	●	●	●	●	●	●	●
Non ferrous metals	○	○	○	○	○	○	○	○	○	○
Heat resistant	○	○	○	○	○	○	○	○	○	○
Hard materials	○	○	○	○	○	○	○	○	○	○

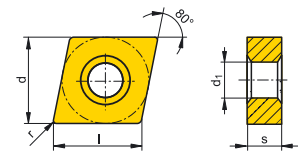

- Main application
- Extended application
- International CERATIZIT range

Ordering example: 10 pieces CNMM 190624SN-R80 CTC1125



For tool holders and boring bars see main catalogue "Tools and inserts for turning", No. 183



Turning inserts

SN.. 15-25



-TMR



-WR



-TRR



-TR



-R88



-HT



-SN..A

r [mm]	Type, description	LNR 	CERATIZIT								l [mm]	d [mm]	s [mm]	d ₁ [mm]		
			CTC3110	MT100	CTC1115	LP2002	CTC1125	CTC1130	CTC1135	LP4002					LP242	CTC2135
1,20	SNMG 150612EN-TMR	N						●					15,88	15,88	6,35	6,35
1,20	SNMM 150612EN-TR	N						●					15,88	15,88	6,35	6,35
1,60	SNMA 150616EN	N	●										15,88	15,88	6,35	6,35
1,20	SNMG 190612EN-TMR	N						●	●	●			19,05	19,05	6,35	7,94
1,20	SNMM 190612-WR	N			●					●			19,05	19,05	6,35	7,94
1,60	SNMA 190616EN	N	●										19,05	19,05	6,35	7,94
1,60	SNMG 190616EN-TMR	N						●				●	19,05	19,05	6,35	7,94
1,60	SNMM 190616EN-TR	N						●	●	●			19,05	19,05	6,35	7,94
1,60	SNMM 190616SN-HT	N		●		●						●				
1,60	SNMM 190616SN-TRR	N						●		●			19,05	19,05	6,35	7,94
1,60	SNMM 190616-WR	N				●	●				●		19,05	19,05	6,35	7,94
2,40	SNMM 190624SN-HT	N				●						●	19,05	19,05	6,35	7,94
2,40	SNMM 190624-WR	N										●	19,05	19,05	6,35	7,94
2,40	SNMM 250724SN-HT	N				●							25,40	25,40	7,94	9,12
2,40	SNMM 250724EN-TR	N			●		●		●				25,40	25,40	7,94	9,12
2,40	SNMM 250724SN-TRR	N			●		●		●				25,40	25,40	7,94	9,12
2,40	SNMM 250724-WR	N				●					●		25,40	25,40	7,94	9,12
3,20	SNMM 250732SN-R88	N				●	●		●				25,40	25,40	7,94	9,12
2,40	SNMM 250924SN-HT	N				●							25,40	25,40	9,52	9,12
2,40	SNMM 250924-WR	N				●					●		25,40	25,40	9,52	9,12
3,20	SNMM 250932SN-R88	N				●	●		●				25,40	25,40	9,52	9,12

	Steel	●	●	●	●	●	●	●	●	●	●
	Stainless	○	○	○	○	○	○	○	○	○	○
	Cast iron	●	●	●	●	●	●	●	●	●	●
	Non ferrous metals	○	○	○	○	○	○	○	○	○	○
	Heat resistant	○	○	○	○	○	○	○	○	○	○
Hard materials											●

- Main application
- Extended application
- International CERATIZIT range

Ordering example: 10 pieces SNMG 150612EN-TMR CTC1125

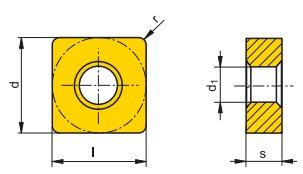

For tool holders and boring bars see main catalogue "Tools and inserts for turning", No. 183



B2-5



B6-B25



B26-B27

Special inserts

B29

Turning inserts

TN.. 22-33

SCMT38



B6

LN..



B7-B8

80°



B9-B10

90°



B11

60°



B12

0°



B13

80°



B14-B15

55°



B16

0°



B17-B20

90°



B21-B23

60°



B24



r [mm]	Type, description	L N R	CTC3110	CTC1115	CTC1125	CTC1130	CTC1135							l [mm]	d [mm]	s [mm]	d ₁ [mm]
0,80	TNMA 220408EN	N	●											22,00	12,70	4,76	5,16
0,80	TNMG 220408EN-TM	N		●	●	●	●							22,00	12,70	4,76	5,16
0,80	TNMG 220408EN-TMR	N			●	●	●							22,00	12,70	4,76	5,16
0,80	TNMG 220408EN-TRM	N			●	●								22,00	12,70	4,76	5,16
0,80	TNMM 220408EN-TR	N			●									22,00	12,70	4,76	5,16
1,20	TNMA 220412EN	N	●											22,00	12,70	4,76	5,16
1,20	TNMG 220412EN-TM	N		●	●		●							22,00	12,70	4,76	5,16
1,20	TNMG 220412EN-TMR	N			●									22,00	12,70	4,76	5,16
1,20	TNMG 220412EN-TRM	N				●	●							22,00	12,70	4,76	5,16
1,20	TNMM 220412EN-TR	N			●		●							22,00	12,70	4,76	5,16
1,20	TNMM 220412SN-TRR	N			●									22,00	12,70	4,76	5,16
1,60	TNMA 220416EN	N	●											22,00	12,70	4,76	5,16
1,60	TNMG 220416EN-TM	N					●							22,00	12,70	4,76	5,16
1,60	TNMG 220416EN-TMR	N			●									22,00	12,70	4,76	5,16
1,60	TNMG 220416EN-TRM	N			●	●								22,00	12,70	4,76	5,16
1,60	TNMM 220416EN-TR	N			●	●								22,00	12,70	4,76	5,16
1,60	TNMM 270616EN-TR	N			●	●								27,50	15,88	6,35	6,35
2,40	TNMG 330924EN	N			●	●	●							33,60	19,05	9,52	7,94
			Steel	●	●	●	●	●	●	●	●	●	●				
			Stainless	○	○	○	○	○	○	○	○	○	○				
			Cast iron	●	●	●	●	●	●	●	●	●	●				
			Non ferrous metals	○	○	○	○	○	○	○	○	○	○				
			Heat resistant	○	○	○	○	○	○	○	○	○	○				
			Hard materials	○	○	○	○	○	○	○	○	○	○				

- Main application
- Extended application
- International CERATIZIT range

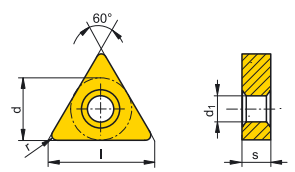

Ordering example: 10 pieces TNMA 220408EN CTC3110



For tool holders and boring bars see main catalogue "Tools and inserts for turning", No. 183



B12



Turning inserts

RCMT 16-32 / CDH 32



-SM

-XR

CDH

d [mm]	Type, description	L N R 								s [mm]	d ₁ [mm]
			CTC1110	CTC1115	LP2002	CTC1125	CTC1130	CTC1135	LP4002		
16,00	RCMT 1606MOSN-SM	N				●	●			6,35	5,30
16,00	RCMT 1606MOSN-XR	N	●	●		●				6,35	5,30
20,00	RCMT 2006MOSN-SM	N						●		6,35	6,50
20,00	RCMT 2006MOSN-XR	N	●	●	●	●			●	6,35	6,50
25,00	RCMT 2507MOSN-SM	N						●		7,94	7,20
25,00	RCMT 2507MOSN-XR	N					●		●	7,94	7,20
32,00	RCMT 3209MOSN-SM	N		●		●				9,52	9,50
32,00	CDH 320900PN-200BF	N							●	9,52	10,00
32,00	CDH 321900PN-200CE	N							●	19,05	10,00



	Steel	Stainless	Cast iron	Non ferrous metals	Heat resistant	Hard materials
CTC1110	●	○	○	○	○	○
CTC1115	●	○	○	○	○	○
LP2002	●	○	○	○	○	○
CTC1125	●	○	○	○	○	○
CTC1130	●	○	○	○	○	○
CTC1135	●	○	○	○	○	○
LP4002	●	○	○	○	○	○
CTS3105	●	○	○	○	○	○

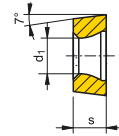
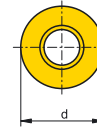

- Main application
- Extended application
- International CERATIZIT range

Ordering example: 10 pieces RCMT 1606MOSN-SM CTC1125



For tool holders and boring bars see main catalogue
"Tools and inserts for turning", No. 183



B2-5



B6-B25



B26-B27

Special
inserts

B29

Turning inserts

CN.. 12-16

SCMT38



B6

LN..



B7-B8

80°



B9-B10

90°



B11

60°



B12

0°



B13

80°



B14-B15

55°



B16

0°



B17-B20

90°



B21-B23

60°



B24



CN..N

r [mm]	Type, description	LNR	TA100	CTN3110	CTS3105											l [mm]	d [mm]	s [mm]
0,40	CNGN 120404TN-020D	N			●											12,90	12,70	4,76
0,80	CNGN 120408TN-020D	N			●											12,90	12,70	4,76
1,20	CNMN 120412FN	N	●													12,90	12,70	4,76
1,20	CNMN 120412TN-020D	N	●													12,90	12,70	4,76
1,20	CNGN 120712PN-100CF	N			●											12,90	12,70	7,94
1,20	CNGN 120712SN-025C	N		●												12,90	12,70	7,94
1,60	CNMN 120416FN	N	●													12,90	12,70	4,76
1,60	CNMN 120416TN-020D	N	●													12,90	12,70	4,76
1,60	CNGN 120716SN-025C	N		●												12,90	12,70	7,94
1,60	CNGN 120716PN-100CF	N			●											12,90	12,70	7,94
1,60	CNGN 120716PN-150CF	N		●												12,90	12,70	7,94
1,60	CNGN 160716SN-200C	N			●											16,10	15,88	7,94
1,60	CNGN 160716SN-025C	N		●												16,10	15,88	7,94

	Steel	●	●	●	●	●	●	●	●	●	●	●	●	●	●	●	●	●
	Stainless	●	●	●	●	●	●	●	●	●	●	●	●	●	●	●	●	●
	Cast iron	●	●	●	●	●	●	●	●	●	●	●	●	●	●	●	●	●
	Non ferrous metals	●	●	●	●	●	●	●	●	●	●	●	●	●	●	●	●	●
	Heat resistant	●	●	●	●	●	●	●	●	●	●	●	●	●	●	●	●	●
	Hard materials	●	●	●	●	●	●	●	●	●	●	●	●	●	●	●	●	●

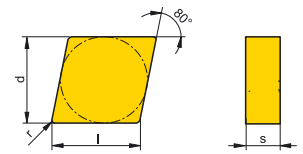

- Main application
- Extended application
- International CERATIZIT range

Ordering example: 10 pieces CNGN 120404TN-020D CTS3105



For tool holders and boring bars see main catalogue "Tools and inserts for turning", No. 183



Turning inserts

ENGN 13



EN..N

r [mm]	Type, description	L N R	CTN3110	CTS3105								l [mm]	d [mm]	s [mm]
0,40	ENGN 130704TN-020D	N		●								13,20	12,70	7,94
0,80	ENGN 130708TN-020D	N		●								13,20	12,70	7,94
1,20	ENGN 130712SN-025E	N	●									13,20	12,70	7,94
1,20	ENGN 130712TN-020D	N		●								13,20	12,70	7,94
1,60	ENGN 130716SN-025E	N	●									13,20	12,70	7,94
1,60	ENGN 130716SN-200C	N		●								13,20	12,70	7,94
3,20	ENGN 130732TN-020D	N		●								13,20	12,70	7,94



Steel	●	●	●	●	●	●	●	●	●	●	●	●	●	●	●
Stainless	●	●	●	●	●	●	●	●	●	●	●	●	●	●	●
Cast iron	●	●	●	●	●	●	●	●	●	●	●	●	●	●	●
Non ferrous metals	●	●	●	●	●	●	●	●	●	●	●	●	●	●	●
Heat resistant	●	●	●	●	●	●	●	●	●	●	●	●	●	●	●
Hard materials	●	●	●	●	●	●	●	●	●	●	●	●	●	●	●

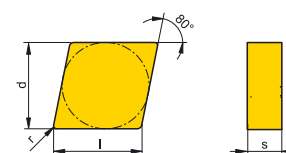

- Main application
- Extended application
- International CERATIZIT range

Ordering example: 10 pieces ENGN 130704TN-020D CTS3105



Tool holders available upon request



B2-5



B6-B25



B26-B27

Special inserts

B29

Turning inserts

DN.. 15

SCMT38



B6

LN..



B7-B8

80°



B9-B10

90°



B11

60°



B12

0°



B13

80°



B14-B15

55°



B16

0°



B17-B20

90°



B21-B23

60°



B24



DN..N

r [mm]	Type, description	LNR	CTS3105															Dimensions		
																		l [mm]	d [mm]	s [mm]
0,40	DNGN 150704TN-020D	N	●															15,50	12,70	7,94
0,80	DNGN 150708TN-020D	N	●															15,50	12,70	7,94
1,20	DNGN 150712TN-020D	N	●															15,50	12,70	7,94
1,20	DNGN 150712SN-200C	N	●															15,50	12,70	7,94
1,60	DNGN 150716PN-100CF	N	●															15,50	12,70	7,94
1,60	DNGN 150716SN-200C	N	●															15,50	12,70	7,94
1,60	DNGN 150716TN-020D	N	●															15,50	12,70	7,94



Material	Steel	Stainless	Cast iron	Non ferrous metals	Heat resistant	Hard materials
Application	●	○	●	○	○	○

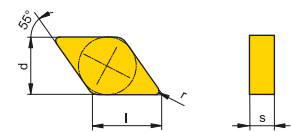

- Main application
- Extended application
- International CERATIZIT range

Ordering example: 10 pieces DNGN 150704TN-020D CTS3105



Tool holders available upon request

B16



Turning inserts

RN.. 06-12



RN..N

d [mm]	Type, description	L N R						s [mm]
			TA100	TA120	CTN3110	CTM3110	CTS3105	
6,35	RNGN 060400TN-020D	N					●	4,76
9,52	RNMN 090300FN	N	●	●				3,18
9,52	RNMN 090300TN-020D	N	●	●				3,18
9,52	RNGN 090400TN-020D	N					●	3,18
12,70	RNMN 120300TN-020D	N	●	●				3,18
12,70	RNMN 120300TN-035D	N		●				3,18
12,70	RNMN 120400FN	N	●					4,76
12,70	RNMN 120400TN-020D	N	●					4,76
12,70	RNGN 120400PN-150CF	N			●	●		4,76
12,70	RNGN 120700PN-100CF	N					●	7,94
12,70	RNGN 120700PN-150CF	N			●			7,94
12,70	RNGN 120700SN-200C	N					●	7,94
12,70	RNGN 120700TN-020D	N					●	7,94



Material	TA100	TA120	CTN3110	CTM3110	CTS3105
Steel	●	●			
Stainless					
Cast iron	●	●	●	●	●
Non ferrous metals					
Heat resistant					
Hard materials	●	●			●



- Main application
- Extended application
- International CERATIZIT range

Ordering example: 10 pieces RNGN 060400TN-020D CTS3105



Tool holders available upon request



B2-5



B6-B25



B26-B27

Special inserts

B29

Turning inserts

RN.. 15-31

SCMT38



B6

LN..



B7-B8

80°



B9-B10

90°



B11

60°



B12

0°



B13

80°



B14-B15

55°



B16

0°



B17-B20

90°



B21-B23

60°



B24



RN..N

d [mm]	Type, description	LNR 	CTN3110				CTM3110				CTS3105				s [mm]
			TA100	CTN3110	CTM3110	CTS3105	TA100	CTN3110	CTM3110	CTS3105	TA100	CTN3110	CTM3110	CTS3105	
15,80	RNGN 150700PN-150CE	N	●											7,94	
15,80	RNGN 150700SN-200C	N				●								7,94	
19,00	RNGN 190700PN-100CF	N					●							7,94	
19,00	RNGN 190700TN-020D	N						●						7,94	
19,00	RNGN 190700PN-150CE	N	●											7,94	
19,00	RNGN 190700SN-200C	N							●					7,94	
25,40	RNMN 250400TN-050D	N	●											4,76	
25,40	RNMN 250600TN-050D	N	●											6,35	
25,40	RNGN 250700PN-100CF	N							●					7,94	
25,40	RNGN 250700PN-200CE	N		●	●									7,94	
25,40	RNGN 250700TN-020D	N								●				7,94	
31,75	RNGN 310900PN-215CF	N		●										9,52	
31,75	RNGN 310900PN-100CF	N								●				9,52	



Steel	●													
Stainless		●												
Cast iron	●	●	●	●	●									
Non ferrous metals														
Heat resistant														
Hard materials	●									●				

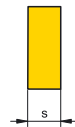

- Main application
- Extended application
- International CERATIZIT range

Ordering example: 10 pieces RNGN 150700PN-150CE CTN3110



Tool holders available upon request

B18



Turning inserts

RCGX 07-12



RC..X

d [mm]	Type, description	L N R	CTN3110	CTS3105													s [mm]				
7,00	RCGX 070400SN-050C	N		●													4,76				
9,52	RCGX 090700PN-075CF	N	●														7,94				
9,52	RCGX 090700PN-100CF	N		●													8,00				
9,52	RCGX 090700SN-200C	N		●													8,00				
9,52	RCGX 090700TN-020D	N		●													8,00				
12,70	RCGX 120700PN-100CF	N		●													8,00				
12,70	RCGX 120700PN-150CF	N	●														7,94				
12,70	RCGX 120700SN-200C	N		●													8,00				
12,70	RCGX 120700TN-020D	N		●													8,00				



Material	CTN3110	CTS3105												
Steel			Blue											
Stainless			Yellow											
Cast iron	●	●	Red											
Non ferrous metals			Green											
Heat resistant			Orange											
Hard materials	●		White											



- Main application
- Extended application
- International CERATIZIT range

Ordering example: 10 pieces RCGX 070400SN-050C CTS3105

	HDCT.. 1RX.. C21				
--	---------------------------------------	--	--	--	--



B2-5



B6-B25



B26-B27

Special inserts

B29

Turning inserts

RCGX 15-25

SCMT38



B6

LN..



B7-B8

80°



B9-B10

90°



B11

60°



B12

0°



B13

80°



B14-B15

55°



B16

0°



B17-B20

90°



B21-B23

60°



B24



RC..X

d [mm]	Type, description	L N R	CTN3110	CTS3105												s [mm]
15,80	RCGX 151000PN-100CF	N	●													10,00
15,80	RCGX 151000PN-150CF	N	●													10,00
15,80	RCGX 151000SN-200C	N	●													10,00
19,05	RCGX 191000PN-200CF	N	●													10,00
19,05	RCGX 191000PN-100CF	N	●													10,00
19,05	RCGX 191000SN-200C	N	●													10,00
25,40	RCGX 251200PN-200CF	N	●													10,00
25,40	RCGX 251200PN-100CF	N	●													10,00
25,40	RCGX 251200SN-200C	N	●													10,00



Steel
Stainless
Cast iron
Non ferrous metals
Heat resistant
Hard materials

Steel	●															
Stainless	●															
Cast iron	●	●														
Non ferrous metals	●															
Heat resistant	●															
Hard materials	●															

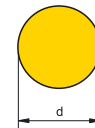

- Main application
- Extended application
- International CERATIZIT range

Ordering example: 10 pieces RCGX 151000PN-100CF CTS3105



HDCT.. 1RX..



C21

B20

Turning inserts

SN.. 12



SN..N

r [mm]	Type, description	L N R	CTC3110	TA100	TA120	CTN3110	CTS3105									l [mm]	d [mm]	s [mm]
0,80	SNGN 120408SN-015D	N					●									12,70	12,70	4,76
0,80	SNGN 120408TN-020D	N					●									12,70	12,70	4,76
1,20	SNMN 120312FN	N		●												12,70	12,70	3,18
1,20	SNMN 120312TN-020D	N		●	●											12,70	12,70	3,18
1,20	SNGN 120412PN-150CF	N					●									12,70	12,70	4,76
1,20	SNGN 120412SN-015D	N					●									12,70	12,70	4,76
1,20	SNGN 120412TN-020D	N					●									12,70	12,70	4,76
1,20	SNMN 120412FN	N		●												12,70	12,70	4,76
1,20	SNMN 120412TN-020D	N		●												12,70	12,70	4,76
1,20	SNUN 120412EN	N	●													12,70	12,70	4,76
1,60	SNMN 120316FN	N		●	●											12,70	12,70	3,18
1,60	SNMN 120316TN-020D	N		●	●											12,70	12,70	3,18
1,60	SNMN 120416FN	N		●												12,70	12,70	4,76
1,60	SNUN 120416EN	N	●													12,70	12,70	4,76
1,60	SNMN 120416TN-020D	N		●												12,70	12,70	4,76
1,60	SNGN 120716PN-100CF	N					●									12,70	12,70	7,94
1,60	SNGN 120716PN-150CF	N					●									12,70	12,70	7,94
1,60	SNGN 120716SN-025C	N					●									12,70	12,70	7,94
1,60	SNGN 120716SN-200C	N					●									12,70	12,70	7,94
1,60	SNGN 120716TN-020D	N					●									12,70	12,70	7,94



Steel	●												
Stainless													
Cast iron	●	●	●	●	●	●	●	●	●	●	●	●	●
Non ferrous metals													
Heat resistant													
Hard materials		●	●			●							

- Main application
- Extended application
- International CERATIZIT range

Ordering example: 10 pieces SNGN 120704TN-020D CTS3105

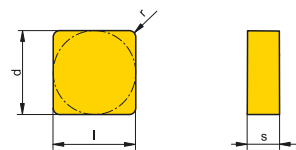

B2-5



B6-B25



B26-B27

Special inserts

B29



Tool holders available upon request



B21

Turning inserts

SNGN 12-15

SCMT38



B6

LN..



B7-B8

80°



B9-B10

90°



B11

60°



B12

0°



B13

80°



B14-B15

55°



B16

0°



B17-B20

90°



B21-B23

60°



B24



SN..N

r [mm]	Type, description	LNR 	CTN3110	CTS3105																				Dimensions				
																								l [mm]	d [mm]	s [mm]		
2,00	SNGN 120720PN-100CF	N		●																					12,70	12,70	7,94	
2,00	SNGN 120720PN-150CF	N	●																							12,70	12,70	7,94
2,00	SNGN 120720SN-200C	N		●																						12,70	12,70	7,94
3,00	SNGN 120730PN-028C	N	●																							12,70	12,70	7,94
1,20	SNGN 150712TN-020D	N		●																						15,80	15,80	7,94
1,60	SNGN 150716PN-150CF	N	●																							15,80	15,80	7,94
2,00	SNGN 150720SN-200C	N		●																						15,80	15,80	7,94



Material	Steel	Stainless	Cast iron	Non ferrous metals	Heat resistant	Hard materials
	●	○	○	○	○	○
	○	○	○	○	○	○
	○	○	○	○	○	○
	○	○	○	○	○	○
	○	○	○	○	○	○
	○	○	○	○	○	○

- Main application
- Extended application
- International CERATIZIT range

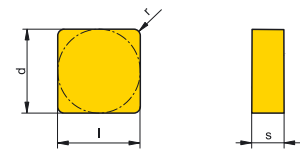

Ordering example: 10 pieces SNGN 120720PN-100CF CTS3105



Tool holders available upon request

B22



Turning inserts

SNGN 19-38



SN..N



SNGN 38..

r [mm]	Type, description	L N R 	CTN3110	CTM3110	CTS3105									l [mm]	d [mm]	s [mm]
1,60	SNGN 190716PN-150CF	N	●	●										19,00	19,00	7,94
1,60	SNGN 190716SN-025E	N	●											19,00	19,00	7,94
1,60	SNGN 190716TN-020D	N			●									19,00	19,00	7,94
2,00	SNGN 190720PN-100CF	N			●									19,00	19,00	7,94
2,00	SNGN 190720SN-200C	N			●									19,00	19,00	7,94
2,00	SNGN 190720TN-020D	N			●									19,00	19,00	7,94
2,40	SNGN 250724PN-100CF	N			●									25,40	25,40	7,94
2,40	SNGN 250724PN-150CE	N	●											25,40	25,40	7,94
2,40	SNGN 250724SN-050C	N			●									25,40	25,40	7,94
2,40	SNGN 250724SN-200C	N			●									25,40	25,40	7,94
2,40	SNGN 250924PN-100CF	N			●									25,40	25,40	9,52
2,40	SNGN 250924PN-150CE	N	●	●										25,40	25,40	9,52
2,40	SNGN 250924SN-030E	N	●											25,40	25,40	9,52
2,40	SNGN 250924SN-200C	N			●									25,40	25,40	9,52
2,40	SNGN 250924TN-020D	N			●									25,40	25,40	9,52
0,40	SNGN 3812RSN-300C	N			●									38,10	38,10	12,70



Steel	●	●	●	●	●	●	●	●	●	●	●	●	●	●	●
Stainless	●	●	●	●	●	●	●	●	●	●	●	●	●	●	●
Cast iron	●	●	●	●	●	●	●	●	●	●	●	●	●	●	●
Non ferrous metals	●	●	●	●	●	●	●	●	●	●	●	●	●	●	●
Heat resistant	●	●	●	●	●	●	●	●	●	●	●	●	●	●	●
Hard materials								●							

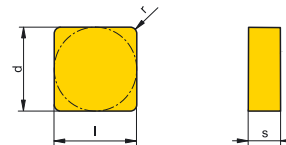

- Main application
- Extended application
- International CERATIZIT range

Ordering example: 10 pieces SNGN 190716PN-150CF CTM3110



Tool holders available upon request



B2-5



B6-B25



B26-B27

Special inserts

B29

Turning inserts

TN.. 16-22

SCMT38



B6

LN..



B7-B8

80°



B9-B10

90°



B11

60°



B12

0°



B13

80°



B14-B15

55°



B16

0°



B17-B20

90°



B21-B23

60°



B24



TN..N

r [mm]	Type, description	LNR	CTC3110	CTS3105														l [mm]	d [mm]	s [mm]
0,80	TNGN 160408TN-020D	N		●														16,50	9,52	4,76
1,20	TNUN 160412EN	N	●															16,50	9,52	4,76
1,60	TNUN 160416EN	N	●															16,50	9,52	4,76
0,80	TNGN 220408TN-020D	N		●														22,00	12,70	4,76



Steel	●																			
Stainless		●																		
Cast iron	●	●																		
Non ferrous metals			●																	
Heat resistant				●																
Hard materials					●															

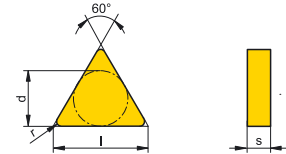

- Main application
- Extended application
- International CERATIZIT range

Ordering example: 10 pieces TNGN 160408TN-020D CTS3105



Tool holders available upon request

B24



Additional turning tools

For additional turning inserts and tools see our main catalogue
"Tools and inserts for turning", No. 183



B2-5



B6-B25



B26-B27

Special
inserts

B29

All inserts and tools from the main catalogue
"Tools and inserts for turning", No. 183
can also be found in our product overview at www.e-techstore.com

 **-TECHSTORE**
www.ceratzit.com



B25

Milling inserts

LNU. 22

90°



B26



ER



SR

l [mm]	Type, description	CTC3215	CTP1235											d [mm]	l ₁ [mm]	s [mm]	r [mm]	d ₁ [mm]		
22	LNUC 220920ER	●													14,28	28,57	9,52	2,00	5,90	
22	LNUJ 220920SR		●												14,28	28,57	9,52	2,00	5,90	
	Steel	●																		
	Stainless	○																		
	Cast iron	●																		
	Non ferrous metals																			
	Heat resistant	○																		
	Hard materials																			



- Steel
- Stainless
- Cast iron
- Non ferrous metals
- Heat resistant
- Hard materials

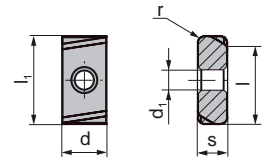

- Main application
- Extended application
- International CERATIZIT range

Ordering example: 10 pieces LNUC 220920ER CTC3215

	AHDM.. C22				
--	---------------------------------	--	--	--	--

Additional inserts for milling

For additional milling inserts and tools see our main catalogue

“Tools and inserts for milling“, No. 126



B2-5



B6-B25



B26-B27

Special
inserts

B29

All inserts from the main catalogue

“Tools and inserts for milling“, No. 126
can also be found in our product overview at www.e-techstore.com

 **-TECHSTORE**
www.ceratzit.com



B27

Special inserts

B29

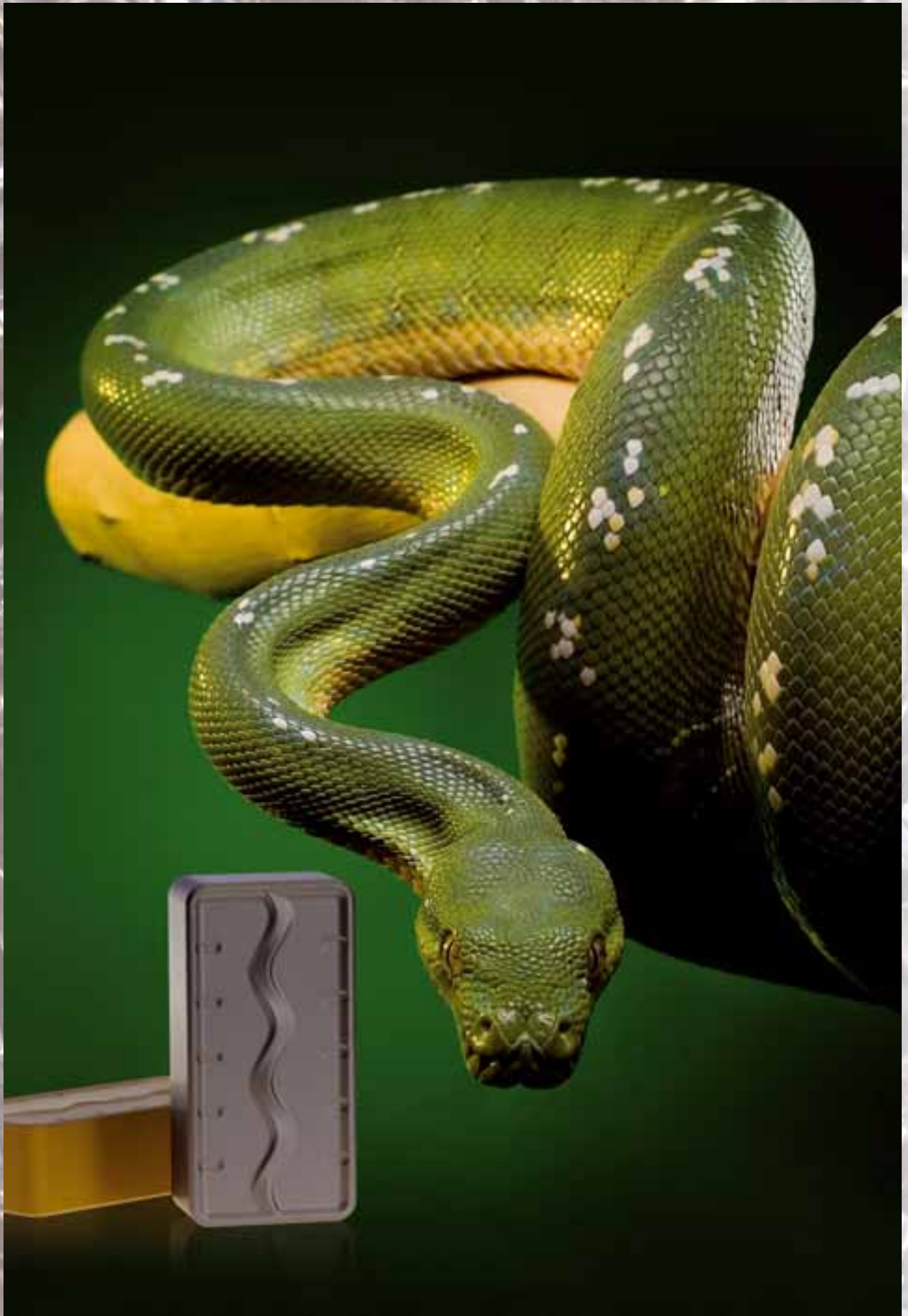

B28

Special inserts upon request



B2-5



B6-B25



B26-B27

Special inserts

B29

Special solutions

Upon request we also produce special inserts with tailored dimensions.

Please enclose a sketch or drawing of your requirements to your request.

For information on production possibilities, delivery time and prices contact us at info.roll@ceratizit.com or send a **fax** to +43 (5672) 200 502.

Tool holders for parting and grooving cartridges HDHGR/L

HDHG..

C2-C4

HDCG..

C5

HDHT..

C6-C17

HDCT..

C18-C21

AHDM..

C22

HDHG...



System C



System K



System W



System H



System S

Picture shows right-hand version

s [mm]	T _{max} [mm]	Type, description	LNR 	Tool holder width [mm]	Availability	
16 20	70	HDHGR C124.G16-070	R	x	■	HDCGN 1HX16P.33 HDCGN 1HX20P.33
	70	HDHGL C124.G16-070	L	x	■	
	70	HDHGR K124.G16-070	R	x	■	
	70	HDHGL K124.G16-070	L	x	■	
	70	HDHGR W96.G16-070	R	x	■	
	70	HDHGL W96.G16-070	L	x	■	
	70	HDHGR H94.G16-070	R	x	■	
	70	HDHGL H94.G16-070	L	x	■	
	70	HDHGR S124.G16-070	R	x	■	
	70	HDHGL S124.G16-070	L	x	■	
25 32	70	HDHGR C124.G25-070	R	x	■	HDCGN 1HX25P.44 HDCGN 1HX32P.44
	70	HDHGL C124.G25-070	L	x	■	
	70	HDHGR K124.G25-070	R	x	■	
	70	HDHGL K124.G25-070	L	x	■	
	70	HDHGR W96.G25-070	R	x	■	
	70	HDHGL W96.G25-070	L	x	■	
	70	HDHGR H94.G25-070	R	x	■	
	70	HDHGL H94.G25-070	L	x	■	
	70	HDHGR S124.G25-070	R	x	■	
	70	HDHGL S124.G25-070	L	x	■	

x Width of tool holder and T_{max} according to customer specification see form on page D11

■ Production upon order / ✓ Available ex stock

	1	2				
HDCGR 1HX..	M8x50 DIN 4762	M10 DIN 580				

	HDCGN 1HX16-20	HDCGN 1HX25-32			
	C5	C5			

Tool holders for parting and grooving cartridges HDHGR/L



HDHG...



System C



System K



System W



System H



System S

Picture shows right-hand version

s [mm]	T _{max} [mm]	Type, description	LNR 	Tool holder width [mm]	Availability	
40 45 50	120	HDHGR C124.G40-120	R	x	■	HDCGN 1HX40P.44 HDCGN 1HX45P.44 HDCGN 1HX50P.44
	120	HDHGL C124.G40-120	L	x	■	
	120	HDHGR K124.G40-120	R	x	■	
	120	HDHGL K124.G40-120	L	x	■	
	120	HDHGR W96.G40-120	R	x	■	
	120	HDHGL W96.G40-120	L	x	■	
	120	HDHGR H94.G40-120	R	x	■	
	120	HDHGL H94.G40-120	L	x	■	
	120	HDHGR S124.G40-120	R	x	■	
120	HDHGL S124.G40-120	L	x	■		

Information: The cartridges for parting and grooving width 16 and 20mm can both be used for the 16mm tool holder. The cartridges for parting and grooving width 25 and 32mm can both be used for the 25mm tool holder. The cartridges for parting and grooving width 40, 45 and 50mm can be used for the 40mm tool holder 40mm.

x Width of tool holder and T_{max} according to customer specification → see form on page D11

■ Production upon order / ✓ Available ex stock

	1	2				
HDCGR 1HX..	M8x50 DIN 4762	M10 DIN 580				

	HDCGN 1HX40-50 					
	C5					



C2-C3



C4



C5



C6-C7



C8



C9



C11



C12-C16



C17-C21



C22-C23

Tool holders with square shank for parting and grooving cartridges 50x50 HX

HDHG..

C2-C4

HDCG..

C5

HDHT..

C6-C17

HDCT..

C18-C21

AHDM..

C22

HDHGN 5050..

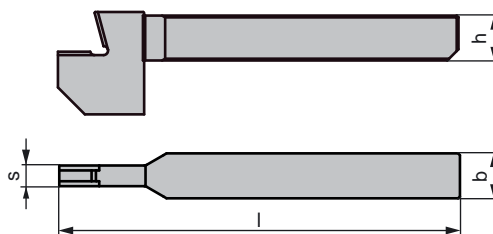







s [mm]	T _{max} [mm]	Type, description	LNR	h [mm]	b [mm]	l [mm]	Availability	
16	70	HDHGN 5050U.G16-070	N	50	50	350	■	HDCGN 1HX16P.33
20	70	HDHGN 5050U.G20-070	N	50	50	350	■	HDCGN 1HX20P.33
25	70	HDHGN 5050U.G25-100	N	50	50	350	■	HDCGN 1HX25P.44
32	70	HDHGN 5050U.G32-100	N	50	50	350	■	HDCGN 1HX32P.44
40	120	HDHGN 5050U.G40-120	N	50	50	350	■	HDCGN 1HX40P.44
45	120	HDHGN 5050U.G45-120	N	50	50	350	■	HDCGN 1HX45P.44
50	120	HDHGN 5050U.G50-120	N	50	50	350	■	HDCGN 1HX50P.44

Information: The cartridges for parting and grooving width 16 and 20mm can both be used for the 16mm tool holder.
The cartridges for parting and grooving width 25 and 32mm can both be used for the 25mm tool holder.
The cartridges for parting and grooving width 40, 45 and 50mm can be used for the 40mm tool holder 40mm.

■ Production upon order / ✓ Available ex stock

Other dimensions upon request → see form on page D11

						
HDCGN 1HX..	1 M8x50 DIN 4762					

	HDCGN 1HX16-20  C5	HDCGN 1HX25-32  C5	HDCGN 1HX40-50  C5		
---	---	---	---	--	--

Parting and grooving cartridges

HX



HDCG...

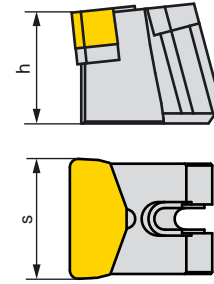

s [mm]	Type, description	Previous designation	LNR 	h [mm]	Availability		
16	HDCGN 1HX16P.33	40488	N	33	✓	HX 16..	pin
20	HDCGN 1HX20P.33	40487	N	33	✓	HX 20..	pin
25	HDCGN 1HX25P.44	40122	N	44	✓	HX 25..	pin
32	HDCGN 1HX32P.44	40120	N	44	✓	HX 32..	pin
40	HDCGN 1HX40P.44	39828	N	44	✓	HX 40..	pin
45	HDCGN 1HX45P.44	40580	N	44	✓	HX 45..	pin
50	HDCGN 1HX50P.44	39942	N	44	✓	HX 50..	pin

Information: The cartridges for parting and grooving width 16 and 20mm can both be used for the 16mm tool holder.
The cartridges for parting and grooving width 25 and 32mm can both be used for the 25mm tool holder.
The cartridges for parting and grooving width 40, 45 and 50mm can be used for the 40mm tool holder 40mm.

■ Production upon order / ✓ Available ex stock

Other dimensions upon request → see form on page D11

	1	2	3
HX 16..	SHIM SEAT HX16 C/40490 GC20	32205-SO	KEY C/26373
HX 20..	SHIM SEAT HX20 C/40489 GC20	32205-SO	KEY C/26373
HX 25..	SHIM SEAT HX25 C/39424 GC20	PIN C/84896	KEY C/26374
HX 32..	SHIM SEAT HX32 C/39425 GC20	PIN C/84896	KEY C/26374
HX 40..	SHIM SEAT HX40 C/39426 GC20	PIN C/84896	KEY C/26374
HX 45..	SHIM SEAT HX45 C/39249 GC20	PIN C/84896	KEY C/26374
HX 50..	SHIM SEAT HX50 C/39412 GC20	PIN C/84896	KEY C/26374

	HX 16-20 B2	HX 25-32 B3	HX 40-50 B4		
--	--------------------	--------------------	--------------------	--	--



C2-C3



C4



C5



C6-C7



C8



C9



C11



C12-C16



C17-C21



C22-C23

C5

Tool holders with integral insert seats

LN.. 66

HDHG..

C2-C4

HDCG..

C5

HDHT..

C6-C17

HDCT..

C18-C21

AHDM..

C22

HDHT...



System C



System K



System W

Picture shows right-hand version

κ [°]	T _{max} [mm]	Connection (system)	No. inserts that can be clamped	Type, description	LNR 	Tool holder width [mm]	Availa- bility	Availability	
10	10	C	2	HDHTR C124.2LN66C.10	R	x	■	LN.. 6688..	top clamp
10	10	C	2	HDHTL C124.2LN66C.10	L	x	■	LN.. 6688..	top clamp
15	15	C	2	HDHTR C124.2LN66C.15	R	x	■	LN.. 6688..	top clamp
15	15	C	2	HDHTL C124.2LN66C.15	L	x	■	LN.. 6688..	top clamp
45	45	C	2	HDHTR C124.2LN66C.45	R	x	■	LN.. 6688..	top clamp
45	45	C	2	HDHTL C124.2LN66C.45	L	x	■	LN.. 6688..	top clamp
87	64	C	2	HDHTR C124.2LN66C.87	R	x	■	LN.. 6688..	top clamp
87	64	C	2	HDHTL C124.2LN66C.87	L	x	■	LN.. 6688..	top clamp
10	10	K	2	HDHTR K124.2LN66C.10	R	x	■	LN.. 6688..	top clamp
10	10	K	2	HDHTL K124.2LN66C.10	L	x	■	LN.. 6688..	top clamp
15	15	K	2	HDHTR K124.2LN66C.15	R	x	■	LN.. 6688..	top clamp
15	15	K	2	HDHTL K124.2LN66C.15	L	x	■	LN.. 6688..	top clamp
45	45	K	2	HDHTR K124.2LN66C.45	R	x	■	LN.. 6688..	top clamp
45	45	K	2	HDHTL K124.2LN66C.45	L	x	■	LN.. 6688..	top clamp
87	64	K	2	HDHTR K124.2LN66C.87	R	x	■	LN.. 6688..	top clamp
87	64	K	2	HDHTL K124.2LN66C.87	L	x	■	LN.. 6688..	top clamp
10	10	W	2	HDHTR W96.2LN66C.10	R	x	■	LN.. 6688..	top clamp
10	10	W	2	HDHTL W96.2LN66C.10	L	x	■	LN.. 6688..	top clamp
15	15	W	2	HDHTR W96.2LN66C.15	R	x	■	LN.. 6688..	top clamp
15	15	W	2	HDHTL W96.2LN66C.15	L	x	■	LN.. 6688..	top clamp
45	45	W	2	HDHTR W96.2LN66C.45	R	x	■	LN.. 6688..	top clamp
45	45	W	2	HDHTL W96.2LN66C.45	L	x	■	LN.. 6688..	top clamp
87	64	W	2	HDHTR W96.2LN66C.87	R	x	■	LN.. 6688..	top clamp
87	64	W	2	HDHTL W96.2LN66C.87	L	x	■	LN.. 6688..	top clamp

x Tool holder width according to customer specification → see form on page D11

■ Production upon order / ✓ Available ex stock

	LN.. 6688.. B7				
--	-----------------------	--	--	--	--

Tool holders with integral insert seats

LN.. 66



HDHT...



System H



System S

Picture shows right-hand version

κ [°]	T _{max} [mm]	Connection (system)	No. inserts that can be clamped	Type, description	LNR 	Tool holder width [mm]	Availa- bility	Picture shows right-hand version	
10	10	H	2	HDHTR H94.2LN66C.10	R	x	■	LN.. 6688..	top clamp
10	10	H	2	HDHTL H94.2LN66C.10	L	x	■	LN.. 6688..	top clamp
15	15	H	2	HDHTR H94.2LN66C.15	R	x	■	LN.. 6688..	top clamp
15	15	H	2	HDHTL H94.2LN66C.15	L	x	■	LN.. 6688..	top clamp
45	45	H	2	HDHTR H94.2LN66C.45	R	x	■	LN.. 6688..	top clamp
45	45	H	2	HDHTL H94.2LN66C.45	L	x	■	LN.. 6688..	top clamp
87	64	H	2	HDHTR H94.2LN66C.87	R	x	■	LN.. 6688..	top clamp
87	64	H	2	HDHTL H94.2LN66C.87	L	x	■	LN.. 6688..	top clamp
10	10	S	2	HDHTR S124.2LN66C.10	R	x	■	LN.. 6688..	top clamp
10	10	S	2	HDHTL S124.2LN66C.10	L	x	■	LN.. 6688..	top clamp
15	15	S	2	HDHTR S124.2LN66C.15	R	x	■	LN.. 6688..	top clamp
15	15	S	2	HDHTL S124.2LN66C.15	L	x	■	LN.. 6688..	top clamp
45	45	S	2	HDHTR S124.2LN66C.45	R	x	■	LN.. 6688..	top clamp
45	45	S	2	HDHTL S124.2LN66C.45	L	x	■	LN.. 6688..	top clamp
87	64	S	2	HDHTR S124.2LN66C.87	R	x	■	LN.. 6688..	top clamp
87	64	S	2	HDHTL S124.2LN66C.87	L	x	■	LN.. 6688..	top clamp

x Tool holder width according to customer specification → see form on page D11

■ Production upon order / ✓ Available ex stock

LN.. 66..	SHIM SEAT LN66 C/34565 GC20	SCREW C/31938	CLAMP C/23216	SCREW C/21409/1	KEY C/26374	M10 DIN 580

	LN.. 6688.. 					
	B7					



C2-C3



C4



C5



C6-C7



C8



C9



C11



C12-C16



C17-C21



C22-C23

Tool holders for turning cartridges

D50

HDHG..

C2-C4

HDCG..

C5

HDHT..

C6-C17

HDCT..

C18-C21

AHDM..

C22

HDHT...



System C



System K



System W



System H



System S

Picture shows right-hand version

Cartridge height	Type, description	LNR 	Tool holder width [mm]	Availability	
50	HDHTR C124.D50	R	x	■	HDCT. .. D50..
50	HDHTL C124.D50	L	x	■	HDCT. .. D50..
50	HDHTR K124.D50	R	x	■	HDCT. .. D50..
50	HDHTL K124.D50	L	x	■	HDCT. .. D50..
50	HDHTR W96.D50	R	x	■	HDCT. .. D50..
50	HDHTL W96.D50	L	x	■	HDCT. .. D50..
50	HDHTR H94.D50	R	x	■	HDCT. .. D50..
50	HDHTL H94.D50	L	x	■	HDCT. .. D50..
50	HDHTR S124.D50	R	x	■	HDCT. .. D50..
50	HDHTL S124.D50	L	x	■	HDCT. .. D50..

x Tool holder width according to customer specification see form on page D11

■ Production upon order / ✓ Available ex stock

	1	2	3			
HDCTR.. D50..	Screw DIN 913 M8x25	Key C/26374	M10 DIN 580			

	HDCT.. D50.. 				
	C18-C21				

Tool holders for standard shanks

SH32



HDHT...



System C



System K



System W



System H



System S

Type, description	LNR 	Tool holder width [mm]	Availability	
HDHTN C124.SH32	N	x	■	25x25 32x25 32x32
HDHTN K124.SH32	N	x	■	
HDHTN W96.SH32	N	x	■	
HDHTN H94.SH32	N	x	■	
HDHTN S124.SH32	N	x	■	

x Tool holder width according to customer specification → see form on page D11

■ Production upon order / ✓ Available ex stock

1	2	3	4	5	
25x25 / 32x25 / 32x32	M16x25 DIN 913	KEY C/26374	10005218/ 125x25x8	10005216/ 120x25x7	F 0,5x5x20,5 DIN 2098
	M10 DIN 580	10002665/M4X20 DIN912-12.9			



For tool holders 25x25, 32x25 and 32x32 see main catalogue "Tools and inserts for turning", No. 183



C2-C3



C4



C5



C6-C7



C8



C9



C11



C12-C16



C17-C21



C22-C23

HDHG..

C2-C4

HDCG..

C5

HDHT..

C6-C17

HDCT..

C18-C21

AHDM..

C22



C10

Tool holders with square shank for turning cartridges S50



HDHT...

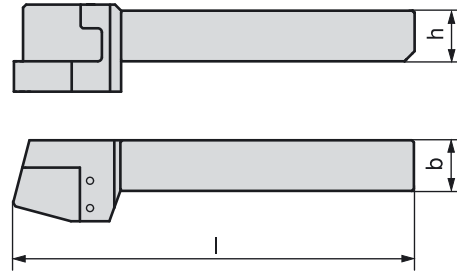

Picture shows right-hand version

h [mm]	Type, description	LNR 	b [mm]	l [mm]	Availability	
60	HDHTR 6060V.S50	R	60	400	■	HDCT.. S50..
60	HDHTL 6060V.S50	L	60	400	■	HDCT.. S50..

x Tool holder width according to customer specification see form on page D11

■ Production upon order / ✓ Available ex stock

	1	2				
HDCT.. S50..	Screw DIN 913 M8x25	Key C/26374				

	HDCT.. S50.. C17				
--	-------------------------	--	--	--	--



C2-C3



C4



C5



C6-C7



C8



C9



C11



C12-C16



C17-C21



C22-C23

Tool holders with square shank and integral insert seat 50x50 LN.. 66

HDHG..

C2-C4

HDCG..

C5

HDHT..

C6-C17

HDCT..

C18-C21



AHDM..

C22

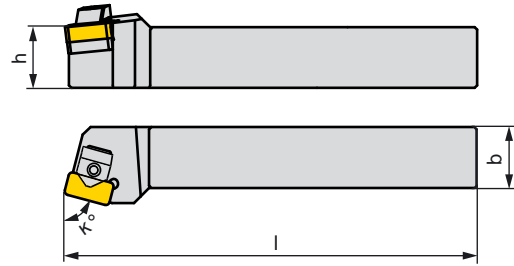





HDHT...





Picture shows right-hand version

κ [°]	h [mm]	Type, description	LNR	b [mm]	l [mm]	Availability		
8	50	HDHTR 5050U.1LN66C.08	R	50	350	✓	LN.. 6688..	top clamp
8	50	HDHTL 5050U.1LN66C.08	L	50	350	■	LN.. 6688..	top clamp
10	50	HDHTR 5050U.1LN66C.10	R	50	350	✓	LN.. 6688..	top clamp
10	50	HDHTL 5050U.1LN66C.10	L	50	350	■	LN.. 6688..	top clamp
15	50	HDHTR 5050U.1LN66C.15	R	50	350	■	LN.. 6688..	top clamp
15	50	HDHTL 5050U.1LN66C.15	L	50	350	■	LN.. 6688..	top clamp
45	50	HDHTR 5050U.1LN66C.45	R	50	350	■	LN.. 6688..	top clamp
45	50	HDHTL 5050U.1LN66C.45	L	50	350	■	LN.. 6688..	top clamp
75	50	HDHTR 5050U.1LN66C.75	R	50	350	✓	LN.. 6688..	top clamp
75	50	HDHTL 5050U.1LN66C.75	L	50	350	■	LN.. 6688..	top clamp
87	50	HDHTR 5050U.1LN66C.87	R	50	350	■	LN.. 6688..	top clamp
87	50	HDHTL 5050U.1LN66C.87	L	50	350	■	LN.. 6688..	top clamp

■ Production upon order / ✓ Available ex stock

						
LN.. 6688..		1	2	3	4	5
		SHIM SEAT LN66 C/34565 GC20	SCREW C/31938	CLAMP C/23216	SCREW C/21409/1	KEY C/26374

	LN.. 6688..  B7						
---	--	--	--	--	--	--	--

Tool holders with square shank and integral insert seat 60x60 LN.. 66



HDHT...

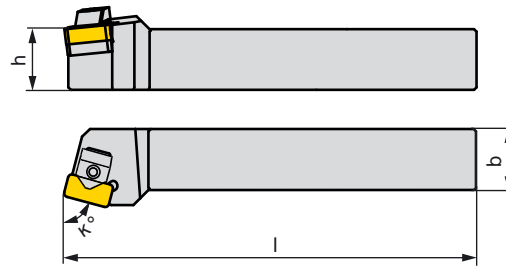

Picture shows right-hand version

κ [°]	h [mm]	Type, description	LNR	b [mm]	l [mm]	Availability		
8	60	HDHTR 6060V.1LN66C.08	R	60	400	✓	LN.. 6688..	top clamp
8	60	HDHTL 6060V.1LN66C.08	L	60	400	■	LN.. 6688..	top clamp
10	60	HDHTR 6060V.1LN66C.10	R	60	400	✓	LN.. 6688..	top clamp
10	60	HDHTL 6060V.1LN66C.10	L	60	400	■	LN.. 6688..	top clamp
15	60	HDHTR 6060V.1LN66C.15	R	60	400	■	LN.. 6688..	top clamp
15	60	HDHTL 6060V.1LN66C.15	L	60	400	■	LN.. 6688..	top clamp
45	60	HDHTR 6060V.1LN66C.45	R	60	400	■	LN.. 6688..	top clamp
45	60	HDHTL 6060V.1LN66C.45	L	60	400	■	LN.. 6688..	top clamp
75	60	HDHTR 6060V.1LN66C.75	R	60	400	✓	LN.. 6688..	top clamp
75	60	HDHTL 6060V.1LN66C.75	L	60	400	■	LN.. 6688..	top clamp
87	60	HDHTR 6060V.1LN66C.87	R	60	400	■	LN.. 6688..	top clamp
87	60	HDHTL 6060V.1LN66C.87	L	60	400	■	LN.. 6688..	top clamp

■ Production upon order / ✓ Available ex stock

LN.. 6688..	SHIM SEAT LN66 C/34565 GC20	SCREW C/31938	CLAMP C/23216	SCREW C/21409/1	KEY C/26374

	LN.. 6688..						
		B7					



C2-C3



C4



C5



C6-C7



C8



C9



C11



C12-C16



C17-C21



C22-C23

C13

Tool holders with square shank and integral insert seat 50x50 LN.. 50

HDHG..

C2-C4

HDCG..

C5

HDHT..

C6-C17

HDCT..

C18-C21

AHDM..

C22

HDHT...

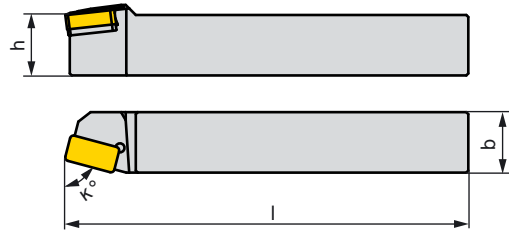

Picture shows right-hand version

κ [°]	h [mm]	Type, description	LN NR	b [mm]	l [mm]	Availability		
75	50	HDHTR 5050U.1LN50C.75	R	50	350	■	LN.. 50..	top clamp
75	50	HDHTL 5050U.1LN50C.75	L	50	350	■	LN.. 50..	top clamp
8	50	HDHTR 5050U.1LN50P.08	R	50	350	■	LN.. 50..	pin
8	50	HDHTL 5050U.1LN50P.08	L	50	350	■	LN.. 50..	pin
10	50	HDHTR 5050U.1LN50P.10	R	50	350	■	LN.. 50..	pin
10	50	HDHTL 5050U.1LN50P.10	L	50	350	■	LN.. 50..	pin
15	50	HDHTR 5050U.1LN50P.15	R	50	350	■	LN.. 50..	pin
15	50	HDHTL 5050U.1LN50P.15	L	50	350	■	LN.. 50..	pin
45	50	HDHTR 5050U.1LN50P.45	R	50	350	■	LN.. 50..	pin
45	50	HDHTL 5050U.1LN50P.45	L	50	350	■	LN.. 50..	pin
75	50	HDHTR 5050U.1LN50P.75	R	50	350	✓	LN.. 50..	pin
75	50	HDHTL 5050U.1LN50P.75	L	50	350	■	LN.. 50..	pin
87	50	HDHTR 5050U.1LN50P.87	R	50	350	■	LN.. 50..	pin
87	50	HDHTL 5050U.1LN50P.87	L	50	350	■	LN.. 50..	pin

■ Production upon order / ✓ Available ex stock

LN.. 50.. Pin clamping	SHIM SEAT LN50 C/39254 GC20	PIN C/84896	KEY C/26374			
LN.. 50.. Top clamp	SHIM SEAT LN50 C/39254 GC20	PION C/41112	KEY C/26374	C/35989	SCREW C/21409/1	

	LN.. 50.. B8					
--	---------------------	--	--	--	--	--

Tool holders with square shank and integral insert seat 60x60 LN.. 50



HDHT...

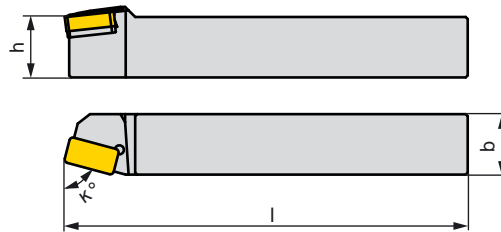

Picture shows right-hand version

κ [°]	h [mm]	Type, description	LN R	b [mm]	l [mm]	Availability		
75	60	HDHTR 6060V.1LN50C.75	R	60	400	■	LN.. 50..	top clamp
75	60	HDHTL 6060V.1LN50C.75	L	60	400	■	LN.. 50..	top clamp
8	60	HDHTR 6060V.1LN50P.08	R	60	400	■	LN.. 50..	pin
8	60	HDHTL 6060V.1LN50P.08	L	60	400	■	LN.. 50..	pin
10	60	HDHTR 6060V.1LN50P.10	R	60	400	■	LN.. 50..	pin
10	60	HDHTL 6060V.1LN50P.10	L	60	400	■	LN.. 50..	pin
15	60	HDHTR 6060V.1LN50P.15	R	60	400	■	LN.. 50..	pin
15	60	HDHTL 6060V.1LN50P.15	L	60	400	■	LN.. 50..	pin
45	60	HDHTR 6060V.1LN50P.45	R	60	400	■	LN.. 50..	pin
45	60	HDHTL 6060V.1LN50P.45	L	60	400	■	LN.. 50..	pin
75	60	HDHTR 6060V.1LN50P.75	R	60	400	✓	LN.. 50..	pin
75	60	HDHTL 6060V.1LN50P.75	L	60	400	■	LN.. 50..	pin
87	60	HDHTR 6060V.1LN50P.87	R	60	400	■	LN.. 50..	pin
87	60	HDHTL 6060V.1LN50P.87	L	60	400	■	LN.. 50..	pin

■ Production upon order / ✓ Available ex stock

LN.. 50.. Pin clamping	SHIM SEAT LN50 C/39254 GC20	PIN C/84896	KEY C/26374			
LN.. 50.. Top clamp	SHIM SEAT LN50 C/39254 GC20	PION C/41112	KEY C/26374	C/35989	SCREW C/21409/1	

	LN.. 50.. B8					
--	---------------------	--	--	--	--	--



C2-C3



C4



C5



C6-C7

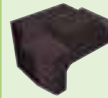

C8



C9



C11



C12-C16



C17-C21



C22-C23

C15

Tool holders with square shank and integral insert seat 50x50 / 60x60 SCMT 38

HDHG..

C2-C4

HDCG..

C5

HDHT..

C6-C17

HDCT..

C18-C21

AHDM..

C22

HDHT...

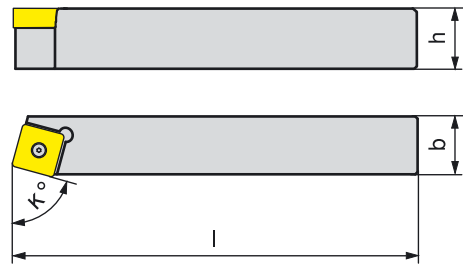

Picture shows right-hand version

κ [°]	h [mm]	Type, description	LNR 	b [mm]	l [mm]	Availability		
75	50	HDHTR 5050U.1SC38S.75	R	50	350	✓	SCMT 38..	screw
75	50	HDHTL 5050U.1SC38S.75	L	50	350	■	SCMT 38..	screw
75	60	HDHTR 6060V.1SC38S.75	R	60	400	✓	SCMT 38..	screw
75	60	HDHTL 6060V.1SC38S.75	L	60	400	■	SCMT 38..	screw

■ Production upon order / ✓ Available ex stock

SCMT 38..	10006168/HM-U SCMT 3809	10004739/B M 8,0	M8X22/T30IP	7883303/ TORX T30			

	SCMT 38.. B6						
--	---------------------	--	--	--	--	--	--

Turning cartridges



Single LN.. 40 / LN.. 50



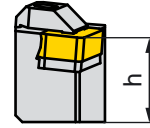



HDHT...









Picture shows right-hand version

κ [°]	Type, description	LN R	h [mm]	Availability		
75	HDCTR 1LN40P.S50.75	R	50	■	LN..40..	pin
75	HDCTL 1LN40P.S50.75	L	50	■	LN..40..	pin
75	HDCTR 1LN50P.S50.75	R	50	■	LN..50..	pin
75	HDCTL 1LN50P.S50.75	L	50	■	LN..50..	pin
75	HDCTR 1LN50C.S50.75	R	50	■	LN..50..	top clamp
75	HDCTL 1LN50C.S50.75	L	50	■	LN..50..	top clamp

■ Production upon order / ✓ Available ex stock

					
1	2	3			
LN.. 40.. Pin clamping	SHIM SEAT LN40 C/38569 GC20	PIN C/84896	KEY C/26374		
LN.. 50.. Pin clamping	SHIM SEAT LN50 C/39254 GC20	PIN C/84896	KEY C/26374		

					
1	2	3	4	5	
LN.. 50.. Top clamp	SHIM SEAT LN50 C/39254 GC20	PION C/41112	KEY C/26374	C/35989	SCREW C/21409/1

	LN.. 40-50		
		B8	

HDHT.. S50			
	C11		

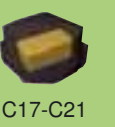

Turning cartridges

Double LN.. 66

HDHG..

C2-C4

HDCG..

C5

HDHT..

C6-C17

HDCT..

HDCT...

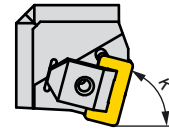
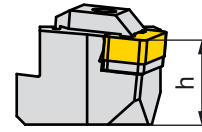
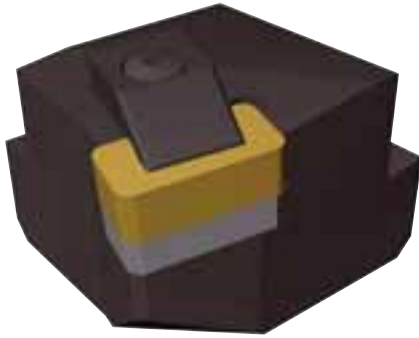

Picture shows right-hand version

C18-C21

AHDM..

C22

κ [°]	Type, description	LN R 	h [mm]	Availa- bility		
5	HDCTR 1LN66C.D50.05	R	50	■	LN..6688..	top clamp
5	HDCTL 1LN66C.D50.05	L	50	■	LN..6688..	top clamp
8	HDCTR 1LN66C.D50.08	R	50	■	LN..6688..	top clamp
8	HDCTL 1LN66C.D50.08	L	50	■	LN..6688..	top clamp
10	HDCTR 1LN66C.D50.10	R	50	■	LN..6688..	top clamp
10	HDCTL 1LN66C.D50.10	L	50	■	LN..6688..	top clamp
15	HDCTR 1LN66C.D50.15	R	50	■	LN..6688..	top clamp
15	HDCTL 1LN66C.D50.15	L	50	■	LN..6688..	top clamp
30	HDCTR 1LN66C.D50.30	R	50	■	LN..6688..	top clamp
30	HDCTL 1LN66C.D50.30	L	50	■	LN..6688..	top clamp
45	HDCTR 1LN66C.D50.45	R	50	■	LN..6688..	top clamp
45	HDCTL 1LN66C.D50.45	L	50	■	LN..6688..	top clamp
60	HDCTR 1LN66C.D50.60	R	50	■	LN..6688..	top clamp
60	HDCTL 1LN66C.D50.60	L	50	■	LN..6688..	top clamp
75	HDCTR 1LN66C.D50.75	R	50	■	LN..6688..	top clamp
75	HDCTL 1LN66C.D50.75	L	50	■	LN..6688..	top clamp
87	HDCTR 1LN66C.D50.87	R	50	■	LN..6688..	top clamp
87	HDCTL 1LN66C.D50.87	L	50	■	LN..6688..	top clamp

■ Production upon order / ✓ Available ex stock

LN.. 66..	SHIM SEAT LN66 C/34565 GC20	SCREW C/31938	CLAMP C/23216	SCREW C/21409/1	KEY C/26374	

	LN..6688.. B7		
--	----------------------	--	--

HDHT.. D50.. C8		
------------------------	--	--

Turning cartridges



Double LN.. 50



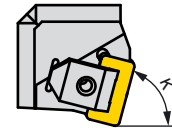
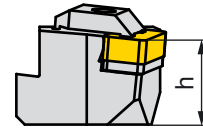
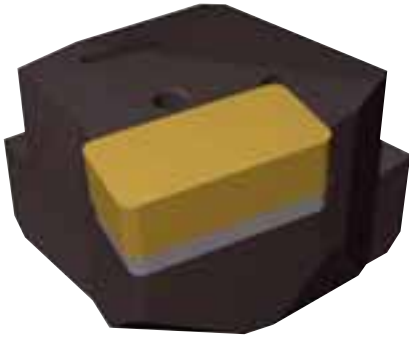









HDCT...



Picture shows right-hand version

κ [°]	Type, description	LNR	h [mm]	Availability		
75	HDCTR 1LN50P.D50.75	R	50	■	LN.. 50..	pin
75	HDCTL 1LN50P.D50.75	L	50	■	LN.. 50..	pin
85	HDCTR 1LN50P.D50.85	R	50	■	LN.. 50..	pin
85	HDCTL 1LN50P.D50.85	L	50	■	LN.. 50..	pin
75	HDCTR 1LN50C.D50.75	R	50	■	LN.. 50..	top clamp
75	HDCTL 1LN50C.D50.75	L	50	■	LN.. 50..	top clamp
85	HDCTR 1LN50C.D50.85	R	50	■	LN.. 50..	top clamp
85	HDCTL 1LN50C.D50.85	L	50	■	LN.. 50..	top clamp

■ Production upon order / ✓ Available ex stock

						
LN.. 50.. Pin clamping	SHIM SEAT LN50 C/39254 GC20	PIN C/84896	KEY C/26374			
						
LN.. 50.. Top clamp	SHIM SEAT LN50 C/39254 GC20	PION C/41112	KEY C/26374	C/35989	SCREW C/21409/1	

	LN..50..			
		B8		

HDHT.. D50..			
	C8		



C2-C3



C4



C5



C6-C7



C8



C9



C11



C12-C16



C17-C21



C22-C23

HDHG..

C2-C4

HDCG..

C5

HDHT..

C6-C17

HDCT..

C18-C21

AHDM..

C22



Turning cartridges

Double RCGX



HDCT...

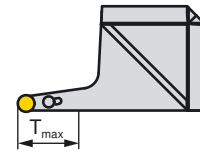
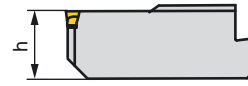

Picture shows right-hand version

T _{max} [mm]	Type, description	L N R 	h [mm]	Availa- bility		
20	HDCTR 1RX12C.D50-020	R	50	■	RCGX 12..	top clamp
20	HDCTL 1RX12C.D50-020	L	50	■	RCGX 12..	top clamp
50	HDCTR 1RX12C.D50-050	R	50	■	RCGX 12..	top clamp
50	HDCTL 1RX12C.D50-050	L	50	■	RCGX 12..	top clamp
75	HDCTR 1RX12C.D50-075	R	50	■	RCGX 12..	top clamp
75	HDCTL 1RX12C.D50-075	L	50	■	RCGX 12..	top clamp
–	HDCTR 1RX25C.D50	R	50	■	RCGX 25..	top clamp
–	HDCTL 1RX25C.D50	L	50	■	RCGX 25..	top clamp

■ Production upon order / ✓ Available ex stock

Other dimensions upon request → see form on page D11

	1	2	3	4	5
RCGX 12..	SHIM SEAT C/24626	THIMBLE DIN1481DIA3X12	CLAMP 27.985-27.981	KEY C/26374	
RCGX 25..	SHIM SEAT C/24629	SPANNHUELSE C/32104	CLAMP C/23216	KEY C/26374	SCREW C/21409/1

	RCGX.. B19-B20		
--	-----------------------	--	--

HDHT.. D50.. C8		
------------------------	--	--



C2-C3



C4



C5



C6-C7



C8



C9



C11



C12-C16



C17-C21



C22-C23

C21

MaxiMill HDM

AHDM

HDHG..

C2-C4

HDCG..

C5

HDHT..

C6-C17

HDCT..

C18-C21

AHDM..

C22

AHDM...

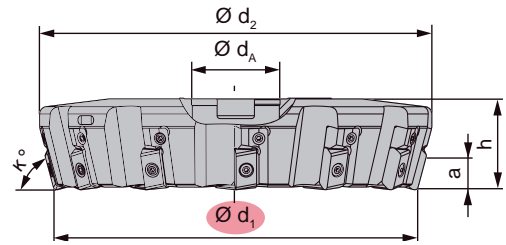

d ₁ [mm]	Type, description	κ° [°]	d ₂ [mm]	h [mm]	a [mm]	d _A [mm]	kg	z	Availability	
160	AHDM.160.R.08-60-22	60	180	63	18	40	9,6	8	■	LNU. 2209..
160	AHDM.160.R.08-75-22	75	171	63	20	40	7,6	8	✓	LNU. 2209..
160	AHDM.160.R.08-90-22	90	160	63	22	40	6,0	8	■	LNU. 2209..
200	AHDM.200.R.10-60-22	60	220	63	18	60	14,0	10	■	LNU. 2209..
200	AHDM.200.R.10-75-22	75	211	63	20	60	11,5	10	✓	LNU. 2209..
200	AHDM.200.R.10-90-22	90	200	63	22	60	9,5	10	■	LNU. 2209..
250	AHDM.250.R.12-60-22	60	270	63	18	60	20,6	12	■	LNU. 2209..
250	AHDM.250.R.12-75-22	75	261	63	20	60	18,6	12	✓	LNU. 2209..
250	AHDM.250.R.12-90-22	90	250	63	22	60	15,9	12	■	LNU. 2209..
315	AHDM.315.R.14-60-22	60	335	80	18	60	44,7	14	■	LNU. 2209..
315	AHDM.315.R.14-75-22	75	326	80	20	60	35,3	14	✓	LNU. 2209..
315	AHDM.315.R.14-90-22	90	315	80	22	60	31,1	14	■	LNU. 2209..

■ Production upon order / ✓ Available ex stock

LNU. 2209..	CA HDM-22-R	10006216/ M5,0x18/T15	DMSD 5,0Nm/ SORT T15			

	LNU. 2209 ..						
		B26					

MaxiMill 260



MaxiMill 260

- Universal application
- Adjustable wiper edges
- Long tool life

- 1 Peripheral milling
- 2 Face milling
- 3 Slot milling
- 4 Shoulder milling

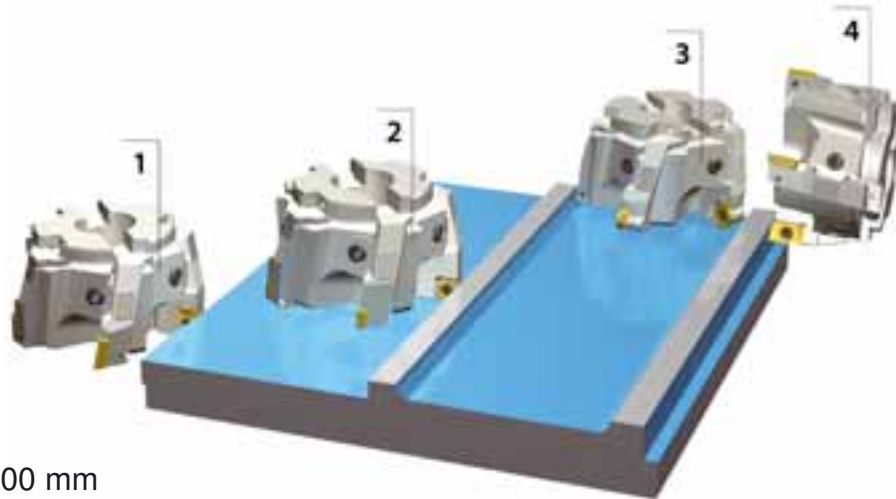

Milling cutters Ø 80-400 mm

> 100 combinations



For more detailed information on this and other milling systems see our main catalogue

“Tools and inserts for milling“,
No. 126



C2-C3



C4



C5



C6-C7



C8



C9



C11



C12-C16



C17-C21



C22-C23

Practical example turning

Success stories

D2-D5

Types of wear

D6-D7

Trouble shooting

D8

General formula

D9

Hardness values

D10

Special tools

D11



Work piece: roll (barrel)

Material: cast iron

Dimensions/ characteristics: length 3500mm
diameter 1160mm
hardness 70-75 ShC

Goals: increased productivity
reduced costs

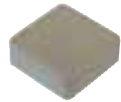

Cutting parameters

	Present situation	Recommendation
Insert	SNGN 25..	SNGN 250724PN-150CE
Grade	P10 (carbide)	CTN3110 (silicon nitride)

Revolution number n [1/min]	4,5	8,5
Feed rate f [mm/min]	7	11
Cutting depth a_p [mm]	4-12	4-12
Number of user inserts	3	3

Production cost savings through the application of a more advanced product from CERATIZIT

cost reduced by 38%

■ Insert cost
■ Insert change cost
■ Machine cost



Practical example parting & grooving



Work piece: roll (barrel)

Material: steel

**Dimensions/
characteristics:** diameter 1300mm
hardness 513 HB

Goals: increased productivity
swarf control
reduced costs



Cutting parameters

	Present situation	Recommendation
Insert	50 mm special insert	HX 50.35.65-R77
Grade	P10	LP105

Revolution number n [1/min]	4,5	10
Feed rate f [mm/min]	5	8
Parting&grooving depth T [mm]	300	300
Total amount of grooves machined	3	3

Production cost savings through the application of a more advanced product from CERATIZIT

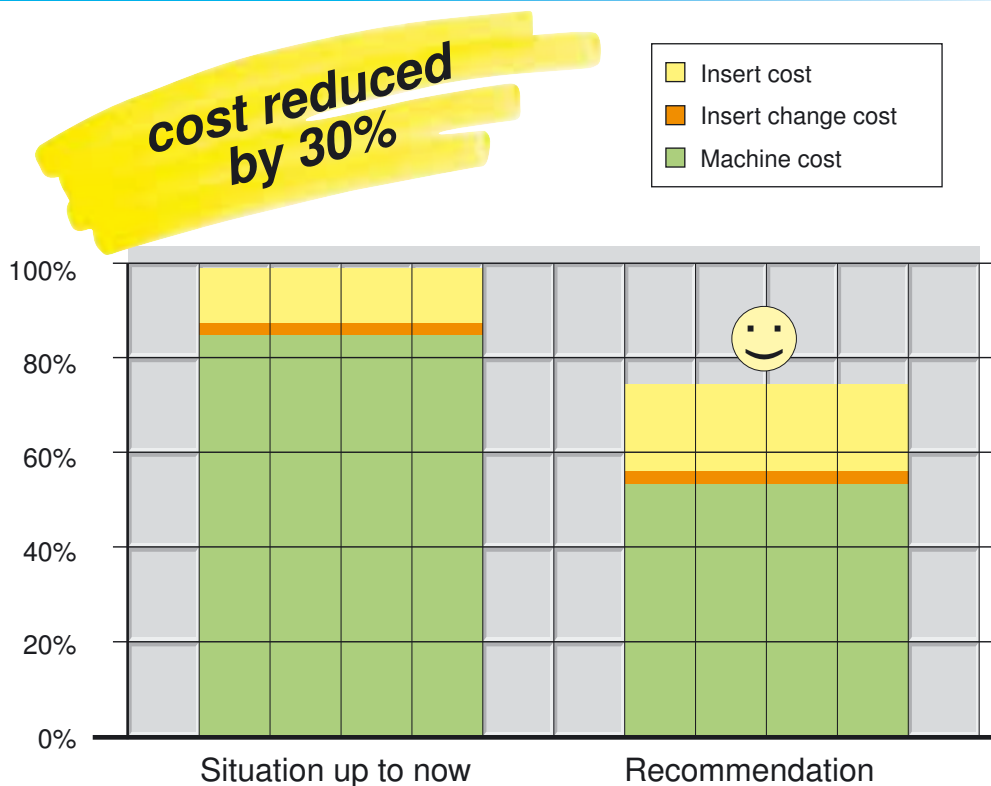

D2-D5

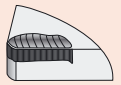

D6-D8

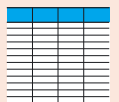

D9-D10

Special tools

D11

D3

Economy of cutting materials

Success stories

The CERATIZIT profitability calculation CT-Wirt

D2-D5

Make use of our calculation tool CT-Wirt to calculate the degree of economy of your cutting materials and to optimize your production costs.

Types of wear

D6-D7

Trouble shooting

D8

General formula

D9

Hardness values

D10

Special tools

D11



The CERATIZIT profitability calculation

Free download from www.cerazit.com

The image displays four overlapping screenshots of the CERATIZIT CT-Wirt software interface. The windows are:

- Variable costs 1:** Shows 'Recommendation' (Turning) and 'Current situation' (Milling). It includes a 'Main cutting time' field with values 318 and 500.
- Variable costs 2:** Shows 'Recommendation' and 'Current situation' for 'Number of cutting edges' with values 4 and 1. It also shows a 'Time' field with value 0,143.
- Results:** A detailed comparison table between 'Recommendation' and 'Current situation' for various cost categories.
- Cost saving:** A small window showing a cost saving of 361,28 EUR and 37,6%.

Category	Recommendation	Current situation
Machine costs per operation	530,00 [EUR]	833,33 [EUR]
Machine costs per operation and batch	530,00 [EUR]	833,33 [EUR]
Costs per cutting edge set	6,45 [EUR]	5,69 [EUR]
Cutting material costs per batch	45,10 [EUR]	79,68 [EUR]
Costs per cutting edge change	3,33 [EUR]	3,33 [EUR]
Costs of cutting edge change per batch	23,31 [EUR]	48,67 [EUR]

D4

Practical example milling



Work piece: roll (spigot)

Material: cast iron
hardness 35-45 ShC

Goals: increased productivity
process security
reduced costs

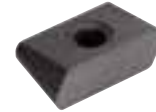

D2-D5

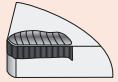

D6-D8

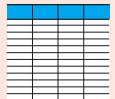

D9-D10

D11

Cutting parameters

	Present situation	Recommendation
Milling system	shell milling cutter Ø 250 mm	AHDM.250.12-75-22
Insert	LNMU 20..	LNUC 220920ER
Grade	K20	CTC3215
Revolution number n [1/min]	91	102
Feed rate f [mm/min]	240	380
Cutting depth a_p [mm]	14	14
Width of cut a_e [mm]	135	135
Insert changes/spigot	4	2

Production cost savings through the application of a more advanced product from CERATIZIT

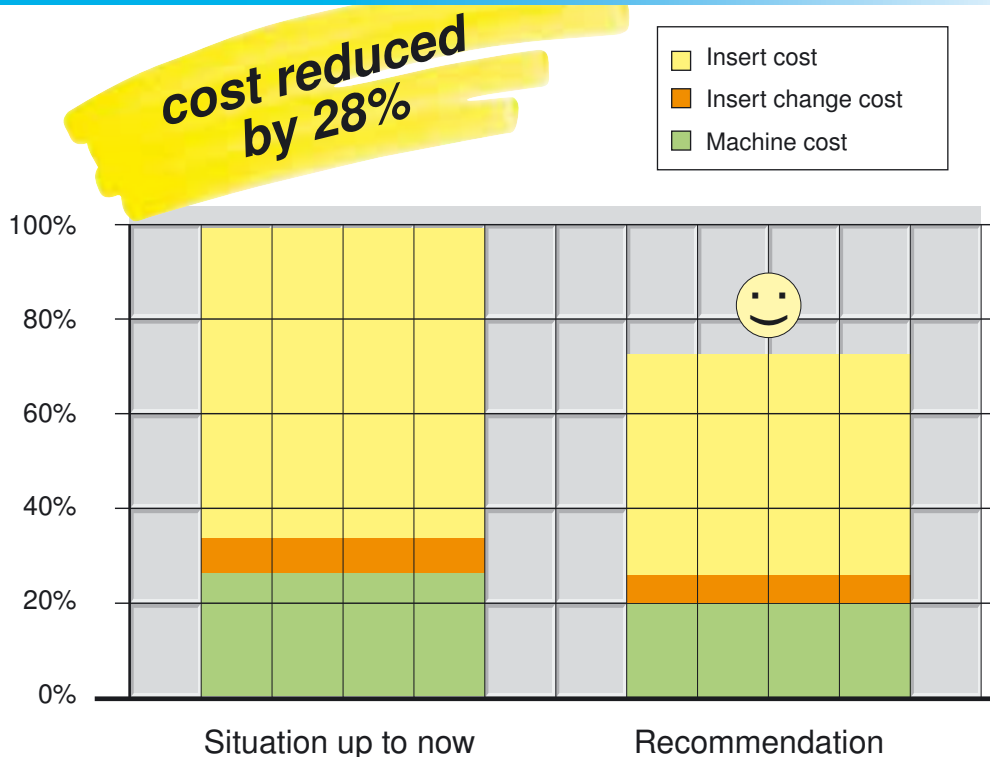

Types of wear

Success stories

D2-D5

Types of wear

D6-D7

Trouble shooting

D8

General formula

D9

Hardness values

D10

Special tools

D11

Flank wear



Abrasion on flank, normal wear after a certain machining time.

Reasons:

- > Cutting speed too high
- > Carbide grade with insufficient wear resistance
- > Feed rate not adapted

Remedies:

- > Reduce cutting speed
- > Select more wear resistant carbide grade
- > Adapt feed rate to cutting speed and cutting depth (increase feed rate)

Edge chipping



Through excessive mechanical stress at the cutting edge fracture and chipping can occur.

Reasons:

- > Grade with too high wear resistance
- > Vibration
- > Feed rate too high or excessive cutting depth
- > Interrupted cut
- > Swarf damage

Remedies:

- > Use tougher grade
- > Use negative cutting edge geometry with chip groove
- > Increase stability (tool, work piece)

Cratering



The hot chip which is being evacuated causes cratering at the rake face of the cutting edge.

Reasons:

- > Too high cutting speed and / or feed rate
- > Rake angle too shallow
- > Grade with low wear resistance
- > Insufficient coolant supply

Remedies:

- > Reduce cutting speed and / or feed rate
- > Increase coolant quantity and / or pressure, optimise coolant supply
- > Use grade which is more resistant to cratering

Types of wear

Plastic deformation



High machining temperature and simultaneous mechanical stress can lead to plastic deformation.

Reasons:

- > Too high machining temperature, resulting in softening of substrate
- > Damaged coatings

Remedies:

- > Reduce cutting speed
- > Choose carbide grade with higher wear resistance
- > Provide cooling

Built-up edge



Built-up material / edge occur when the chip is not evacuated properly due to insufficient cutting temperature.

Reasons:

- > Too low cutting speed
- > Too small rake angle
- > Wrong cutting material
- > Lack of cooling / lubrication

Remedies:

- > Increase cutting speed
- > Enlarge rake angle
- > Apply TiN-coating
- > Use emulsion with higher concentration

Insert breakage



Excessive stress of the insert causes breakage.

Reasons:

- > Excessive stress of cutting material
- > Lack of stability
- > Corner angle too small
- > Excessive notching

Remedies:

- > Use tougher cutting material
- > Use protective edge chamfer
- > Increase honing of edge
- > Use more stable geometry



D2-D5

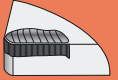

D6-D8

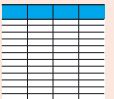

D9-D10

D11

Corrective measures for turning problems

Success stories

D2-D5

Types of wear

D6-D7

Trouble shooting

D8

General formula

D9

Hardness values

D10

Special tools

D11

Type of problem												Corrective measures											
Type of wear						Work piece problems			Swarf control		Cutting speed			Feed rate	Feed - centre area	Chip groove	Corner radius	Cutting material	Clamping of tool	Clamping of work piece	Overhang	Tip height	Cooling lubricant
Flank wear	Cratering	Edge chipping	Plastic deformation	Insert breakage	Built-up edge	Vibration	Formation of pips and burrs	Chattered surface	Surface quality	Chip too long (tangled swarf)													
↓	↓		↓		↑	↓			↑	↓													
~		↓	↓	↓		↑		↓	↓	↑	↓												
	↓	↓					↓	↓	↓														
		↑	~		↓	~	↓	↓	↓	↓	↑												
↑		↑	↑			↓	↓	↓	↑														
↑	↑	↓	↑	↓																			
		~		~		~	~	~															
		~		~		~	~	~															
		~		~		~	~	~	↓														
~		~				~	~		~														
●	~		●		●		●		●	●													

↑ raise, increase, large influence

↓ avoid, reduce large influence

~ check, optimize

↑ raise, increase low influence

↓ avoid, reduce low influence

● use

General formula

Turning, milling

Cutting speed [m/min]

$$v_c = \frac{d \cdot \pi \cdot n}{1000}$$

Revolution number [1/min]

$$n = \frac{v_c \cdot 1000}{\pi \cdot d}$$

Specific formulas for turning

Feed rate [mm/rev]

$$f = \frac{V_f}{n}$$

Chip cross section [mm²]

$$A = a_p \cdot f$$

Specific formulas for milling

Feed rate [mm/min]

$$v_f = f \cdot n = f_z \cdot z \cdot n \quad [\text{mm/min}]$$

Metal removal rate [mm³/min]

$$Q = a_p \cdot a_e \cdot v_f \quad [\text{mm}^3/\text{min}]$$

Legend:

v_c cutting speed [m/min]
 d roll diameter [mm]
 n revolution number [1/min]
 π 3.141592
 f feed rate [mm/rev]
 V_f feed rate [mm/min]

A chip cross section [mm²]
 a_p depth of cut [mm]
 z number of teeth
 f_z feed rate/tooth [mm]
 Q metal removal rate [mm³/min]
 a_e width of cut [mm]

The CERATIZIT formula collection CT-CALC



The CERATIZIT
formula collection

Free download from www.ceratizit.com

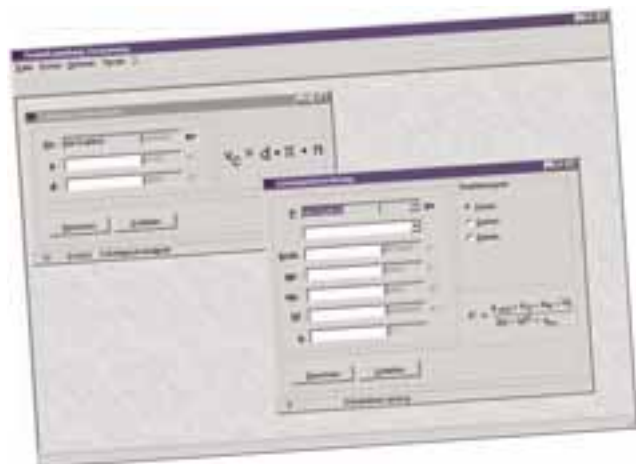

D2-D5

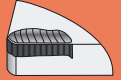

D6-D8

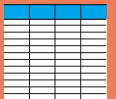

D9-D10

D11

Hardness values

Comparison chart

Success stories

D2-D5

Types of wear

D6-D7

Trouble shooting

D8

General formula

D9

Hardness values

D10

Special tools

D11

Tensile strength N/mm ²	Vickers HV	Brinell HB	Rockwell HRC	Shore C
575	180	171		
595	185	176		
610	190	181		
625	195	185		
640	200	190	12,0	
660	205	195	13,0	
675	210	199	14,0	
690	215	204	15,0	
705	220	209	15,5	28
720	225	214	16,0	
740	230	219	17,0	29
755	235	223	18,0	
770	240	228	20,3	30
785	245	233	21,3	
800	250	238	22,2	31
820	255	242	23,1	32
835	260	247	24,0	33
850	265	252	24,8	
865	270	257	25,6	
880	275	261	26,4	34
900	280	268	27,1	
915	285	271	27,8	35
930	290	276	28,5	
950	295	280	29,2	36
965	300	285	29,8	37
995	310	295	31,0	38
1030	320	304	32,2	39
1060	330	314	33,3	40
1095	340	323	34,3	41
1125	350	333	35,5	42
1155	360	342	36,6	43
1190	370	352	37,7	44
1220	380	361	38,8	45
1255	390	371	39,8	46
1290	400	380	40,8	47
1320	410	390	41,8	48
1350	420	399	42,7	
1385	430	409	43,6	49
1420	440	418	44,5	
1455	450	428	45,3	51
1485	460	437	46,1	52
1520	470	447	46,9	53
1555	480	465	47,7	54
1595	490	466	48,4	
1630	500	475	49,1	57
1665	510	485	49,8	58
1700	520	494	50,5	59
1740	530	504	51,1	60

Tensile strength N/mm ²	Vickers HV	Brinell HB	Rockwell HRC	Shore C
1775	540	513	51,7	61
1810	550	523	52,3	62
1845	560	532	53,0	63
1880	570	542	53,6	64
1920	580	551	54,1	65
1955	590	561	54,7	66
1995	600	570	55,2	67
2030	610	580	55,7	68
2070	620	589	56,3	69
2105	630	599	56,8	70
2145	640	608	57,3	71
2180	650	618	57,8	72
2210	660	628	58,3	73
2240	665	633	58,8	74
2280	670	638	59,3	
2310	675	643	59,8	75
2350	680	648	60,3	76
2380	685	653	61,1	77
2410	690	658	61,3	78
2450	695	663	61,7	79
2480	710	668	62,2	80
2520	720	678	62,6	81
2550	730	683	63,1	82
2590	740	693	63,5	
2630	750	703	63,9	83
2660	760	708	64,3	84
2700	770	718	64,7	85
2730	780	723	65,1	
2770	790	733	65,5	86
2800	800	738	65,9	
2840	810	748	66,3	87
2870	820	753	66,7	88
2910	830	763	67,0	
2940	840	768	67,4	89
2980	850		67,7	
3010	860		68,1	90
3050	870		68,4	
3080	880		68,7	91
3120	890		69,0	
3150	900		69,3	92
3190	910		69,6	
3220	920		69,9	
3260	930		70,1	

The figures given are approximate according to DIN EN ISO18265 (02-2004)

HD special tools

Enquiry form for special heavy duty tools

Special tool refers to (please indicate tool below)

- Tool holder with integral insert seat
- Tool holder for turning cartridges
- Tool holder for parting & grooving cartridges
- Tool holder for standard shanks
- Tool holder with square shank for turning cartridges
- Tool holder with square shank for parting & grooving cartridges
- Tool holder with square shank and integral insert seat
- Turning cartridge
- Parting & grooving cartridge
- Other special shape
-
-

Type of modification:

- Approach angle degrees
- Insert seat mm
- Shank length mm
- Other modification
-
- Tool holder width mm
- Maximum parting & grooving depth mm
- Shank width and height x mm

If possible please enclose a sketch or drawing of your requirements.

For information on production possibilities, delivery time and prices contact us at info.roll@ceratizit.com or send a fax to +43 (5672) 200 502.



D2-D5

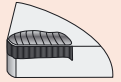

D6-D8

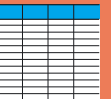

D9-D10

D11



D11



CERATIZIT – bar peeling

Delivery programme

In addition to products for roll machining CERATIZIT also offers an extensive programme for bar peeling.

- Cutting inserts for all applications
- Complete tooling programme including cutter heads, tool holders, cartridges
- Guide parts such as rolls and axles



You can find our complete programme
in our main catalogue
“Tools and inserts for bar peeling”,
No. 174

CONTACT:
info.bar@ceratizit.com





Lined writing area consisting of 30 horizontal grey lines on a white background, intended for text entry.

CERATIZIT – worldwide

CERATIZIT – worldwide

- Production sites in the three big economic areas with a worldwide network of CERATIZIT sales and support engineers plus many CERATIZIT distribution partners guarantee customer vicinity.
- We maintain the dialogue with our customers and strive for long-term partnerships.

Find your personal distribution partner at:

www.ceratizit.com



- CERATIZIT worldwide production sites and support centres
- CERATIZIT worldwide sales centres
- CERATIZIT worldwide distribution partner network

CERATIZIT - worldwide

Parent company in Luxembourg

CERATIZIT Luxembourg Sàrl
Route de Holzem 101, B.P. 51
L-8201 Mamer

Tel.: +352 312 085-1
Fax: +352 311 911
E-mail: info@ceratizit.com
www.ceratizit.com

Contact for further information:

CERATIZIT Austria Gesellschaft m.b.H.
A-6600 Reutte/Tyrol

Tel.: +43 (5672) 200-0
Fax: +43 (5672) 200-502
E-mail: info.austria@ceratizit.com
www.ceratizit.com



459

www.ceratizit.com - just a click.



hard material matters



459 EN 08.08
7001768

We reserve the right to make technical changes for improvement of the product.